

# ASSEMBLY INSTRUCTIONS

## MANUAL DE MONTAGEM / INSTRUCCIONES DE ARMADO

Resende office table  
Mesa Resende  
Escritorio Resende

Reference  
Referência  
Referencia **1105**

Revise  
Revisão  
Revisión **12**

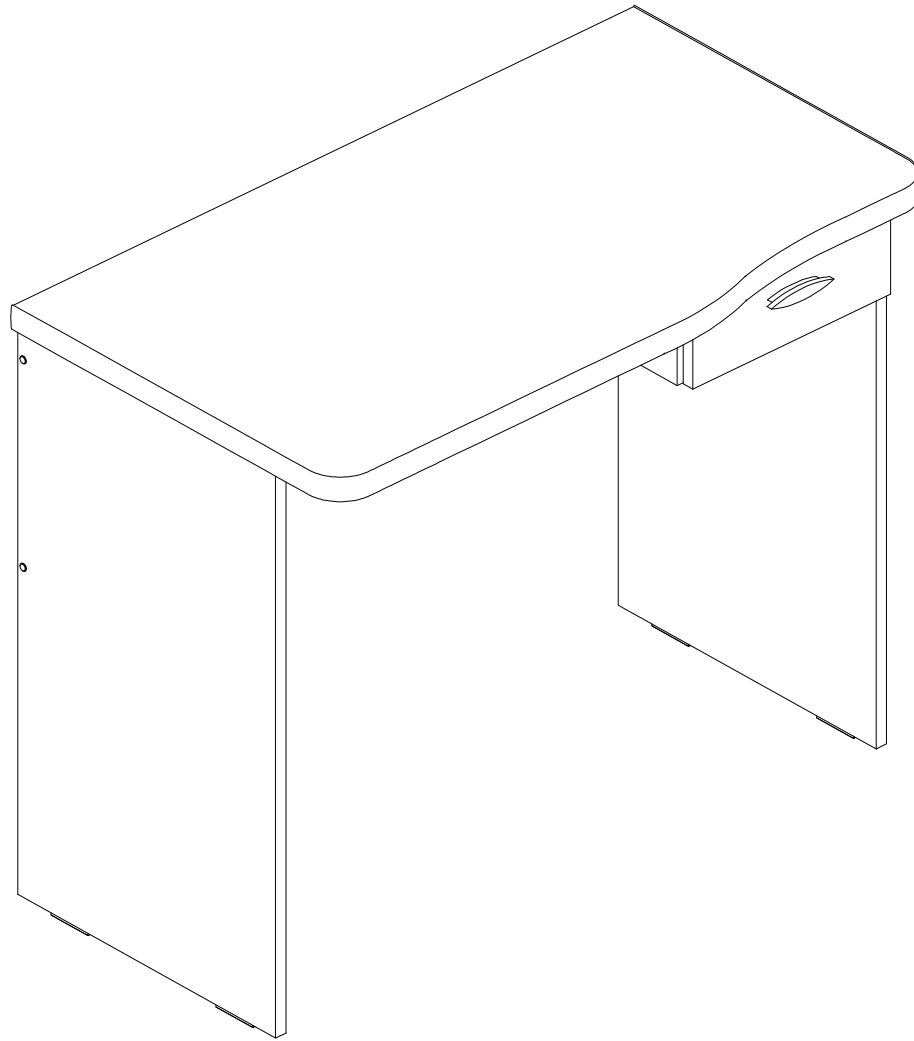

### YOU WILL NEED / VOCÊ VAI PRECISAR DE / USTED NECESITARÁ

#### Tools not supplied / Ferramentas não fornecidas / Herramientas no incluidas

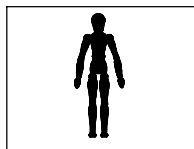

1 Person  
1 Pessoa  
1 Persona

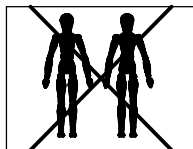

2 People  
2 Pessoas  
2 Personas

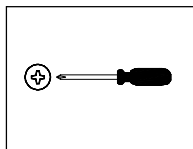

Screwdriver Phillips  
Chave Phillips  
Destornillador cruz

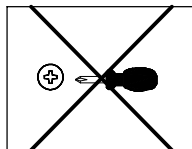

Small screwdriver Phillips  
Chave Phillips Menor  
Destornillador cruz menor

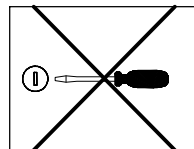

Screwdriver slotted  
Chave fenda  
Destornillador plano

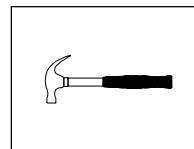

Hammer  
Martelo  
Martillo

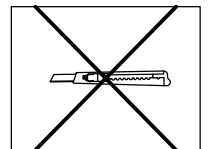

Stylet  
Estilete  
Estilete

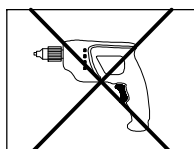

Drill machine  
Furadeira  
Taladro

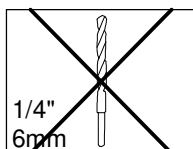

Drill bit  
Broca  
Taladro

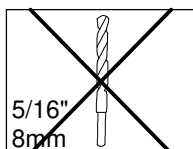

Drill bit  
Broca  
Taladro

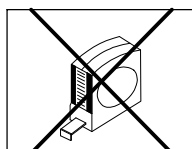

Measuring tape  
Trena  
Cinta de medición

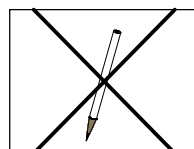

Pencil  
Lápis  
Lápis

**NOTES:** The separation of the accessories before you start the assembly will facilitate the same. In case of doubt on the size of the screws and bolts, use the ruler to bottom of page 3.

**NOTAS:** A separação dos acessórios antes de iniciar a montagem facilitará a mesma. Em caso de dúvida no tamanho dos parafusos e cavilhas, utilize a régua ao final da página 3.

**NOTAS:** La separación de los accesorios antes de comenzar el armado facilitará el mismo. En caso de duda sobre el tamaño de los tornillos y taquetes, utilice la regla al pie de página 3.

MAXIMUM RECOMMENDED WEIGHT  
BEING THIS EVENLY DISTRIBUTED

PESO MÁXIMO RECOMENDADO SENDO  
ESTE DISTRIBUÍDO UNIFORMEMENTE

PESO MÁXIMO RECOMENDADO SIENDO  
ESTE UNIFORMEMENTE DISTRIBUIDO

	LB	KG
<b>A</b>	55	25
<b>B</b>	2,2	1

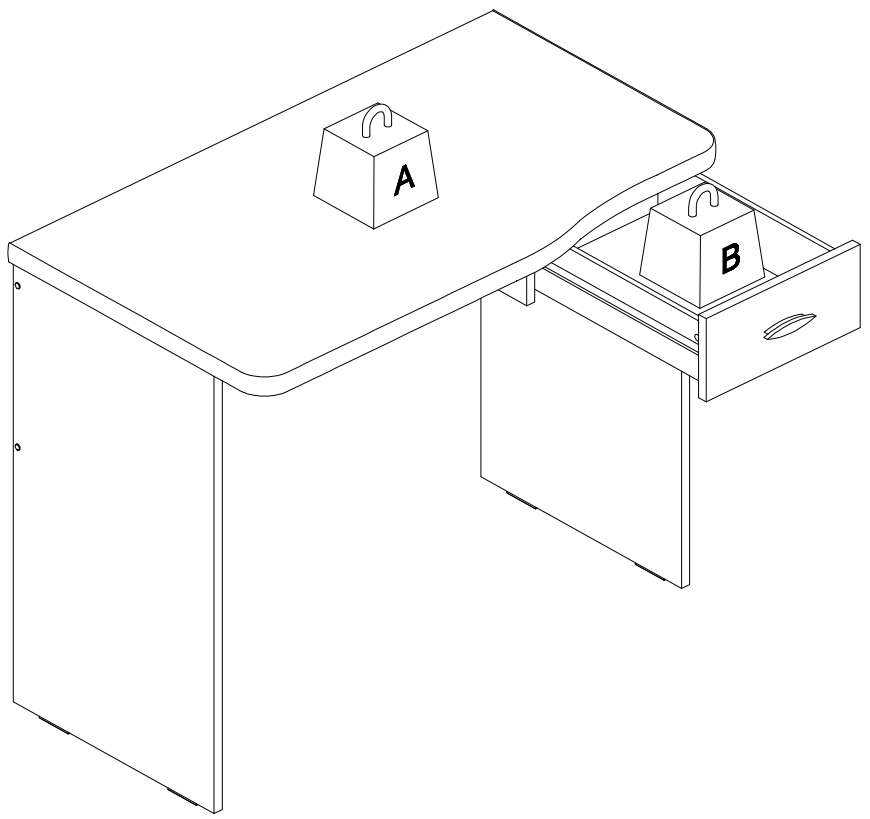





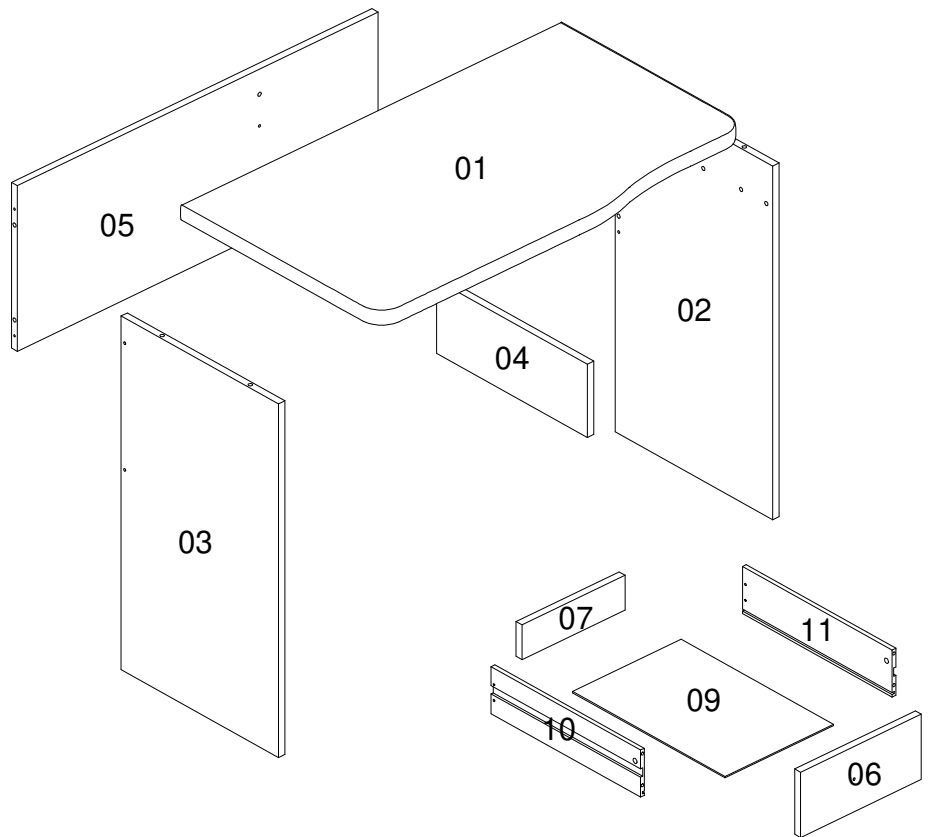







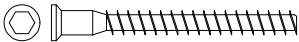

Nº	Measures Inches	Medidas cm	Qty./Qtd.
01	35 1/4 x 19 7/8 x 5/8	89,6 x 50,5 x 1,5	1
02	28 1/8 x 15 3/4 x 5/8	71,5 x 40 x 1,5	1
03	28 1/8 x 15 3/4 x 5/8	71,5 x 40 x 1,5	1
04	15 1/8 x 5 7/8 x 5/8	38,4 x 14,8 x 1,5	1
05	13 1/4 x 33 1/2 x 5/8	33,5 x 85,1 x 1,5	1
06	11 1/4 x 5 1/4 x 5/8	28,5 x 13,2 x 1,5	1
07	9 5/8 x 3 1/8 x 5/8	24,4 x 8 x 1,5	1
09	15 1/8 x 9 7/8 x 1/8	38,4 x 25,2 x 0,3	1
10	15 x 3 3/4 x 3/8	38 x 9,5 x 0,9	1
11	15 x 3 3/4 x 3/8	38 x 9,5 x 0,9	1

**PARTS IDENTIFICATION**  
**IDENTIFICAÇÃO DAS PEÇAS / IDENTIFICACIÓN DE LAS PIEZAS**

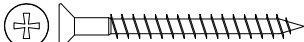
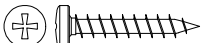

## IDENTIFICATION OF ACCESSORIES IDENTIFICAÇÃO DOS ACESSÓRIOS/ IDENTIFICACIÓN DE ACCESORIOS

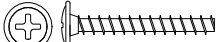
A1		Glue / Cola / Pegamento	13 g	1
A3		Trapeze / Trapézio / Trapecio	-	2
A4		Metalic bracket / Cantoneira de metal / Suporte de metal	22x22 mm	5
B1		Plastic Foot / Sapata / Pie Plástico	15x58 mm	4
D8		Flat head screw / Parafuso chato / Tornillo de cabeza plana	3,0x30 mm	4
D9		Plastic slide/ Corrediza plástica / Corredera plástica	280mm	2
E		Wooden dowel / Cavilha / Taquete	8x30 mm	9
F1		Wooden dowel / Cavilha / Taquete	6x30 mm	4
F2		Handle / Puxador 91 / Tirador	32 mm	1
G		Structural screw / Parafuso estrutural / Tornillo estructural	5,0x50 mm	4
H		Allen key / Chave allen / Liave allen	3 mm	1
I		Structural screw cover/Tampa parafuso estrutural/Tapa tornillo estructural	-	4
N		Nail / Prego / Clavo	10x10	3
O		Flat head screw / Parafuso chato / Tornillo de cabeza plana	4,5x45 mm	1
P		Pan head screw / Parafuso panela / Tornillo de pan	4,5x25 mm	2
S		Pan head screw / Parafuso panela / Tornillo de pan	3,5x14 mm	10
T		Flanged head screw / Parafuso flangeado / Tornillo de cabeza flangeada	3,5x25 mm	2



PRE-ASSEMBLE  
PRÉ-MONTAGEM / PRE ARMADO

01

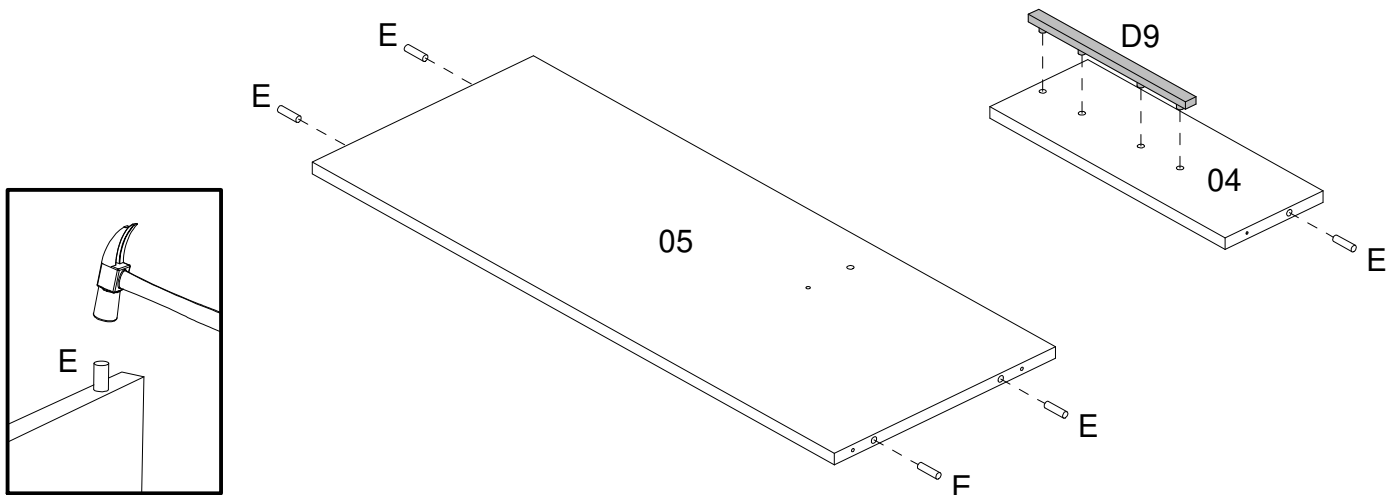

02

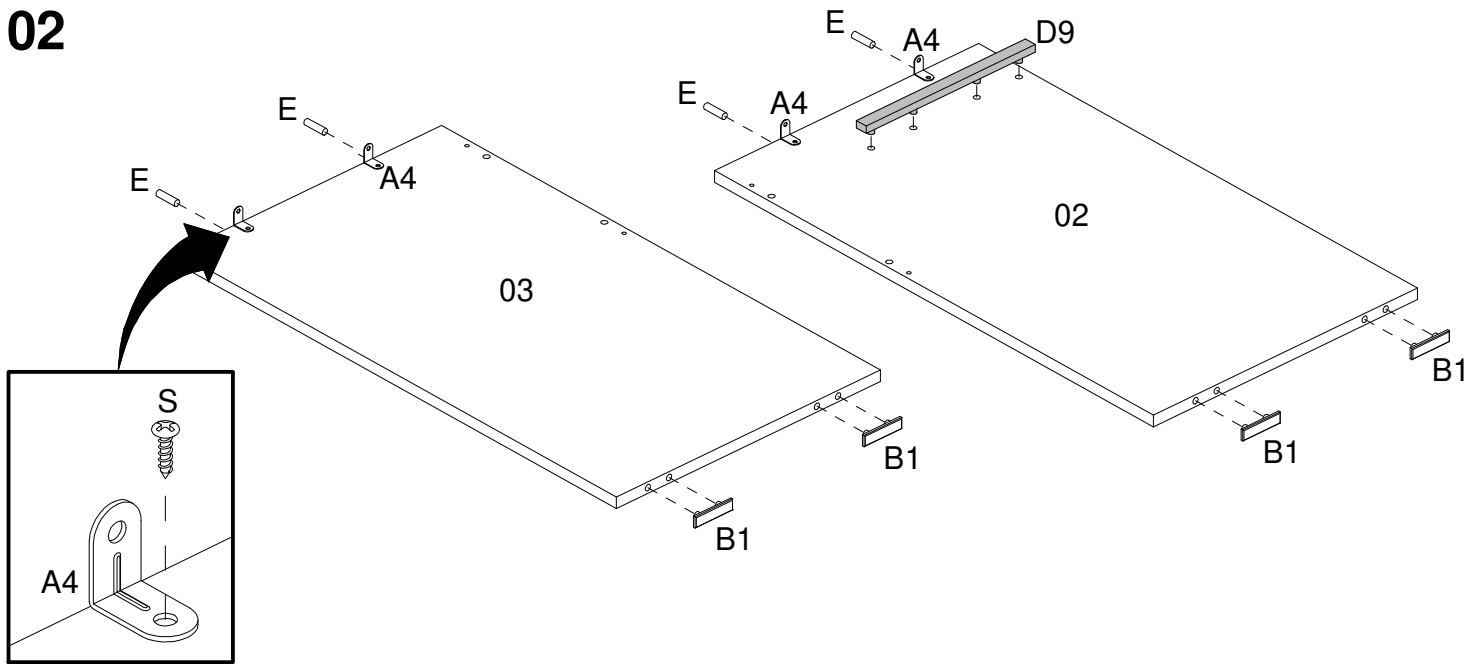

03

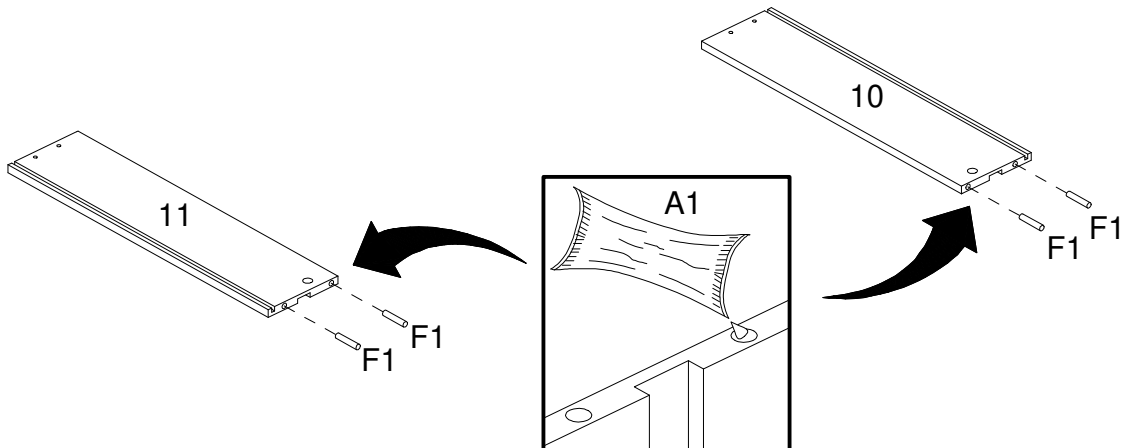

ASSEMBLY  
MONTAGEM / ARMADO

04

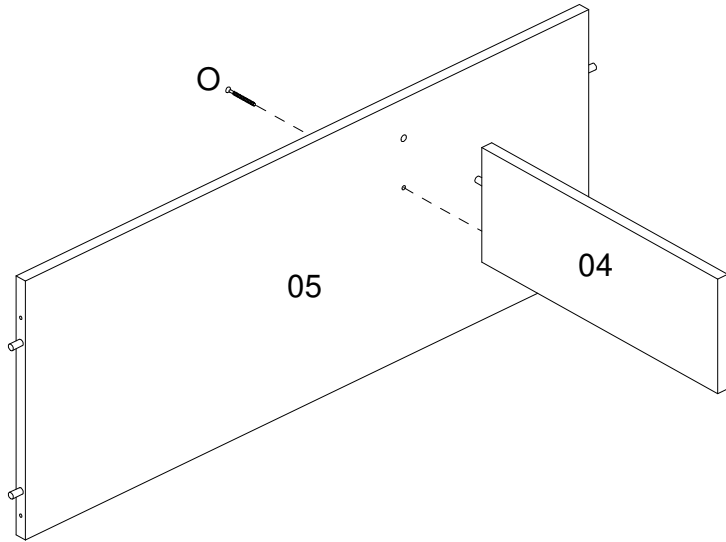

05

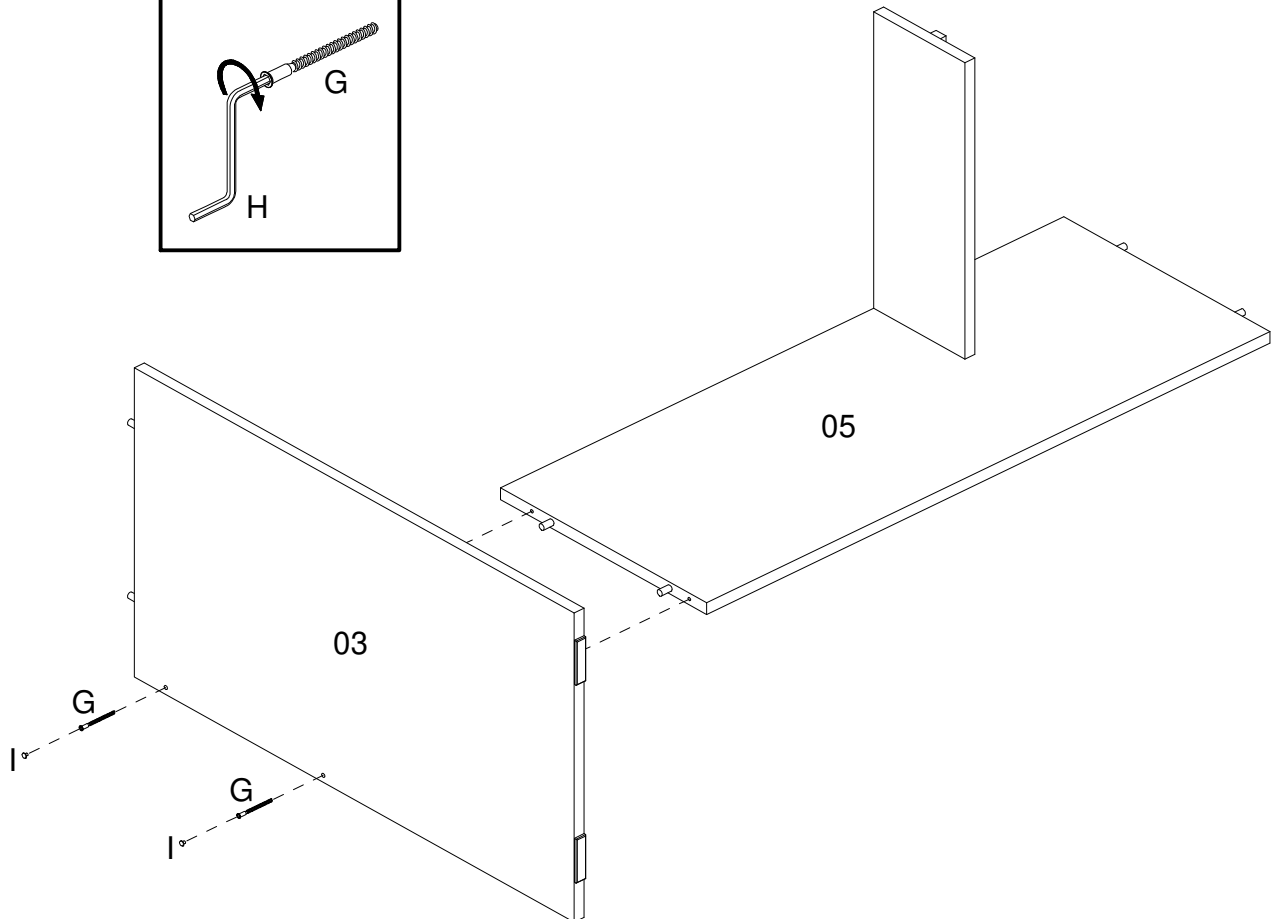
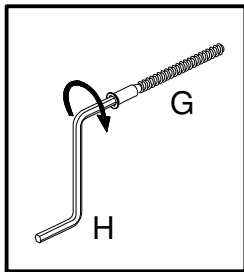

06

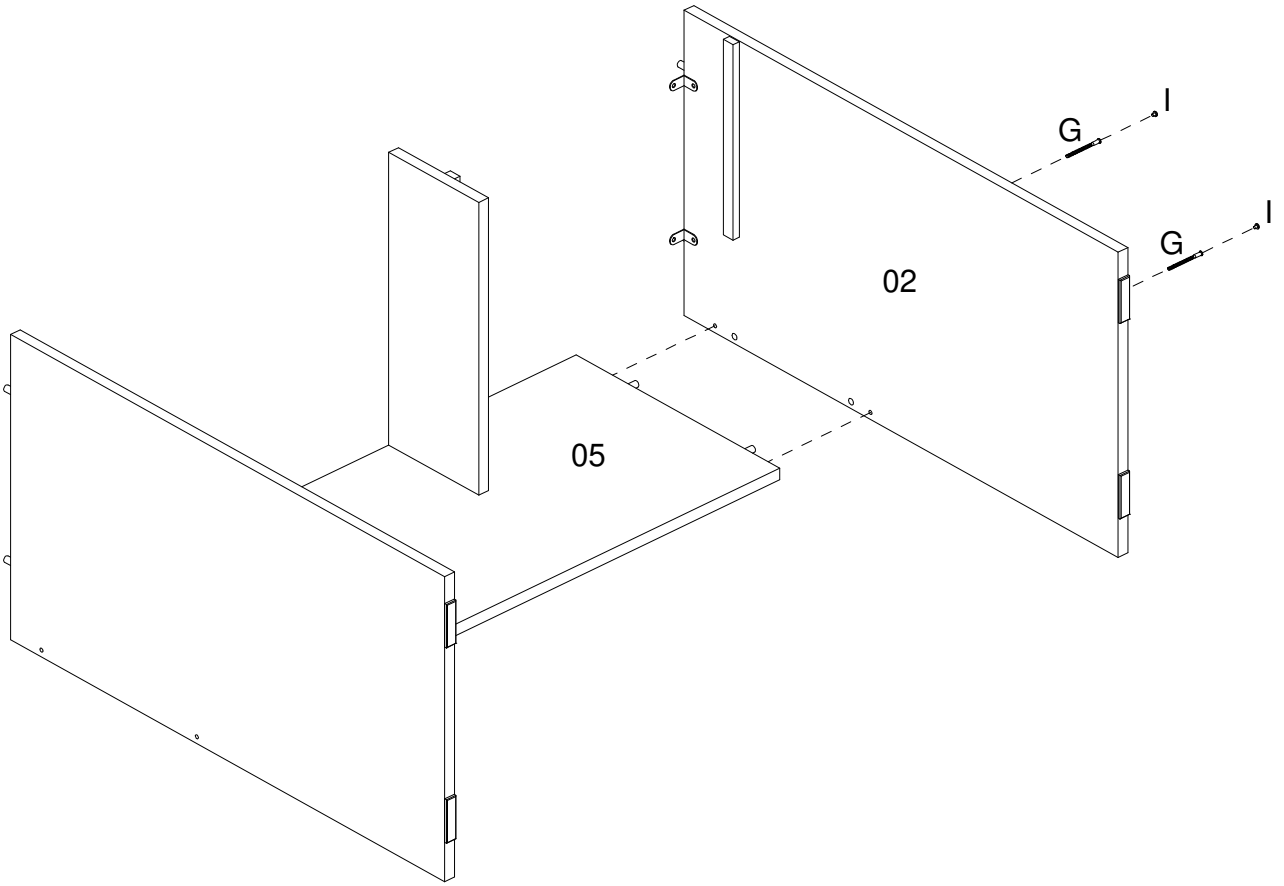

07

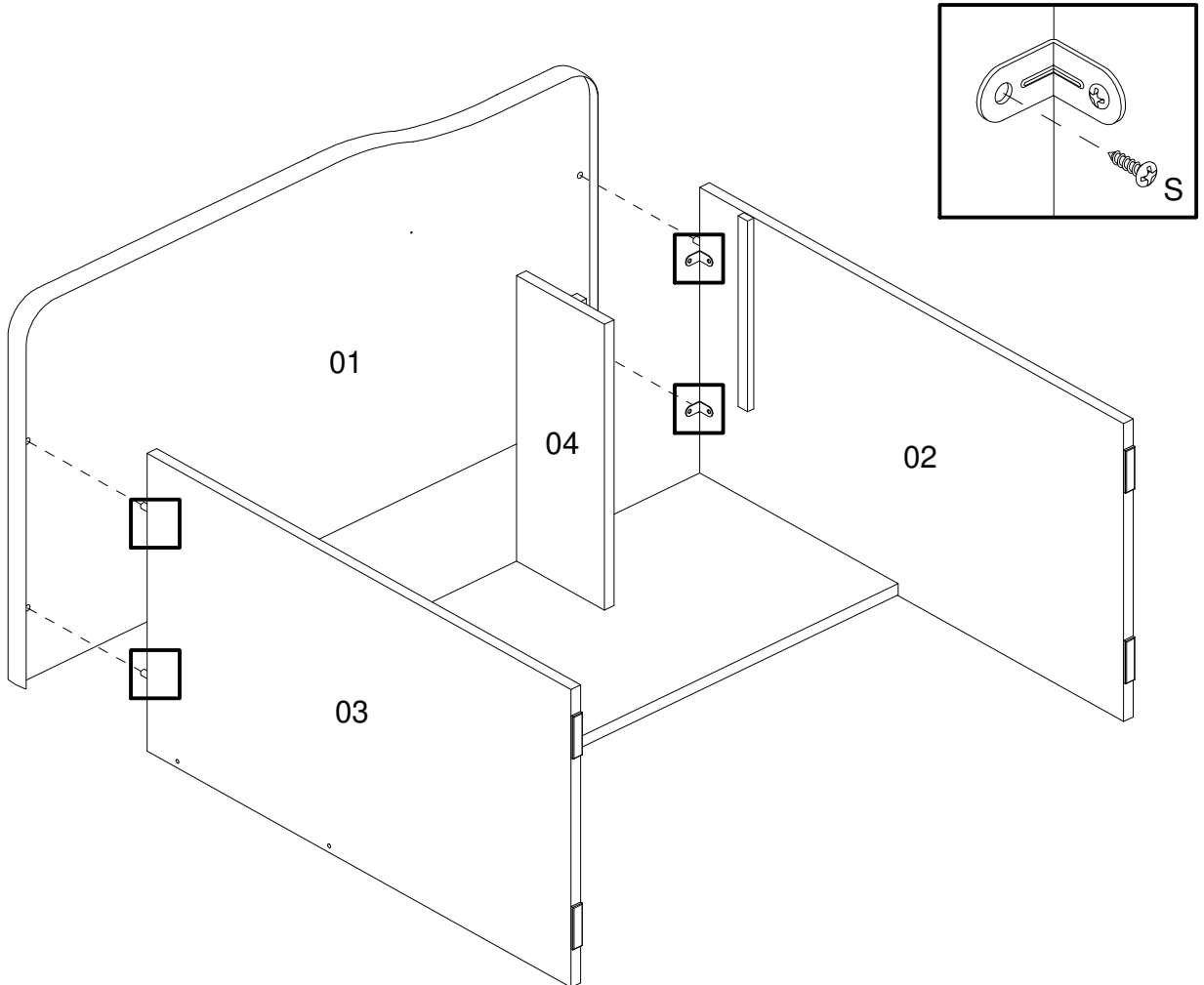

08

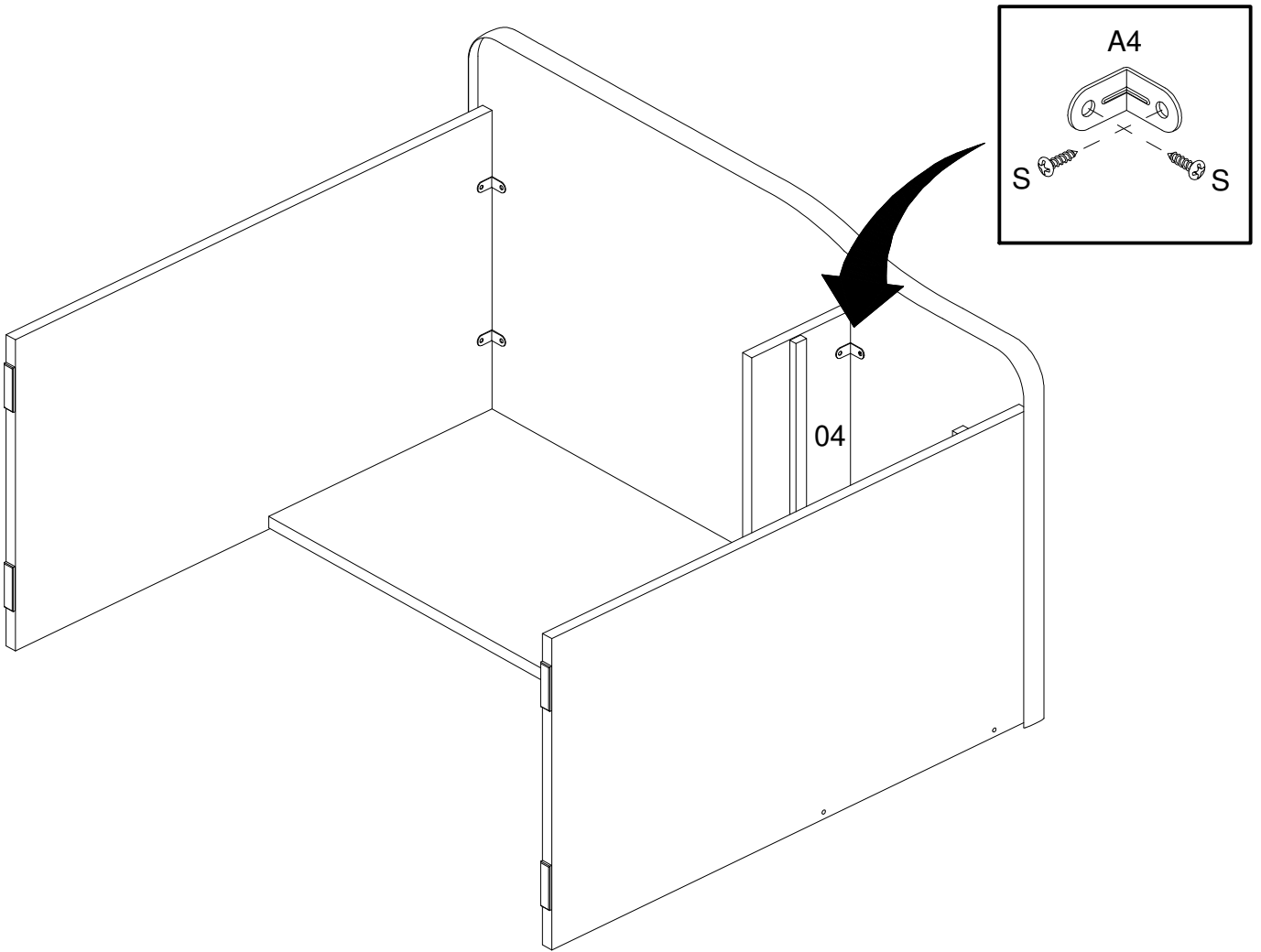

09

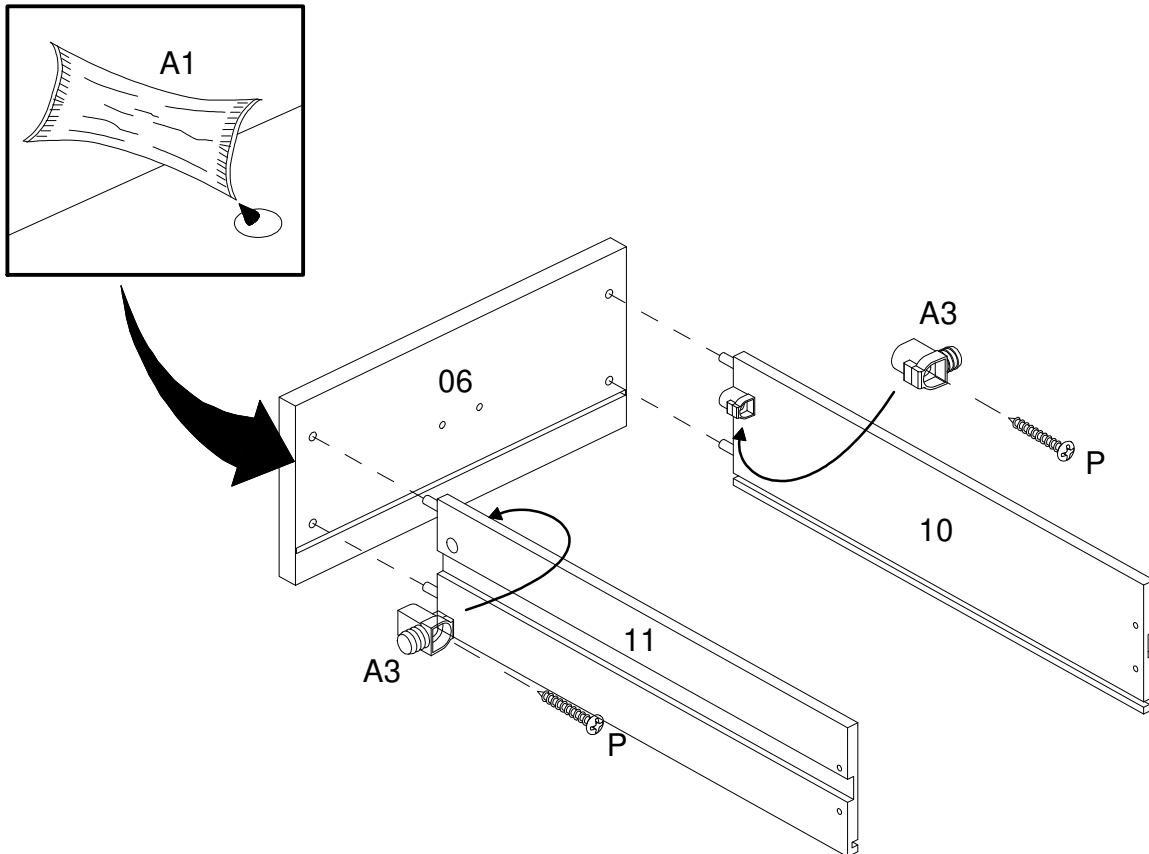

10

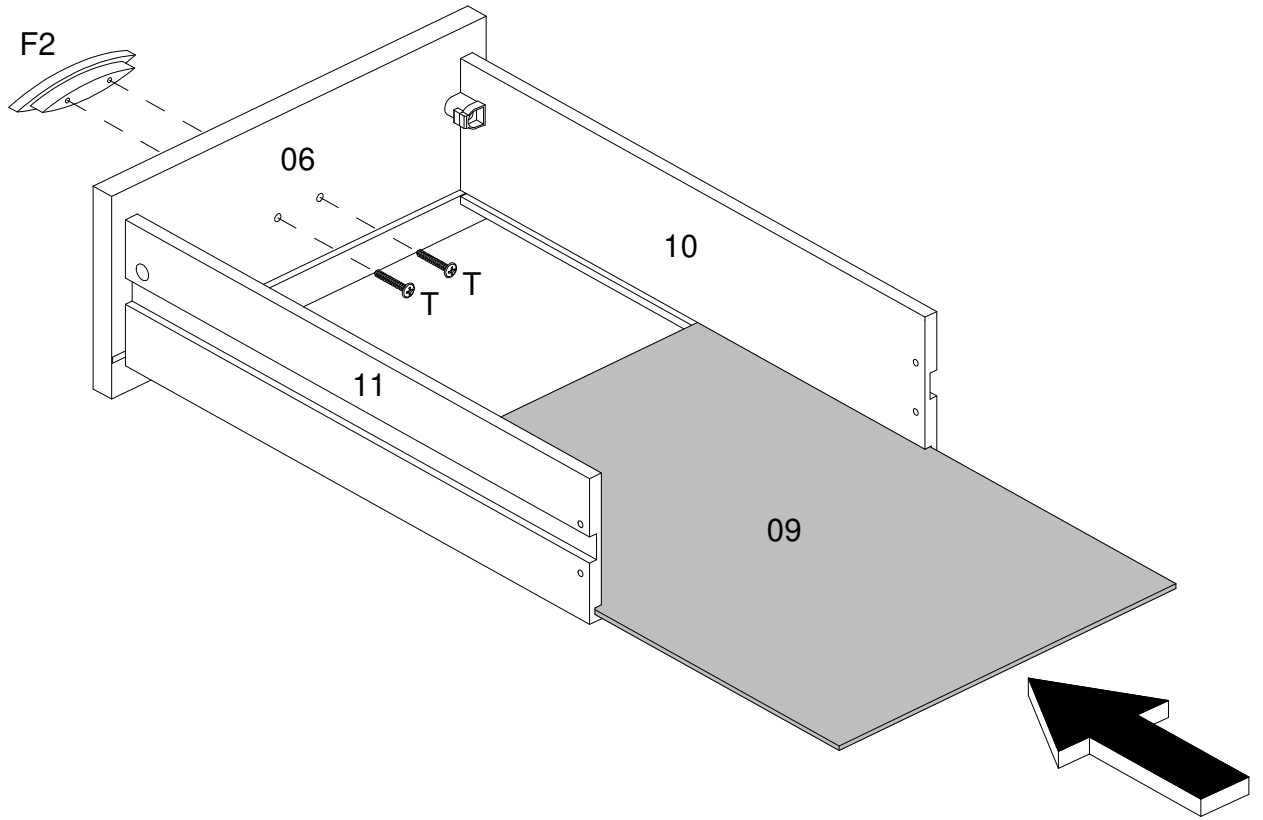

11

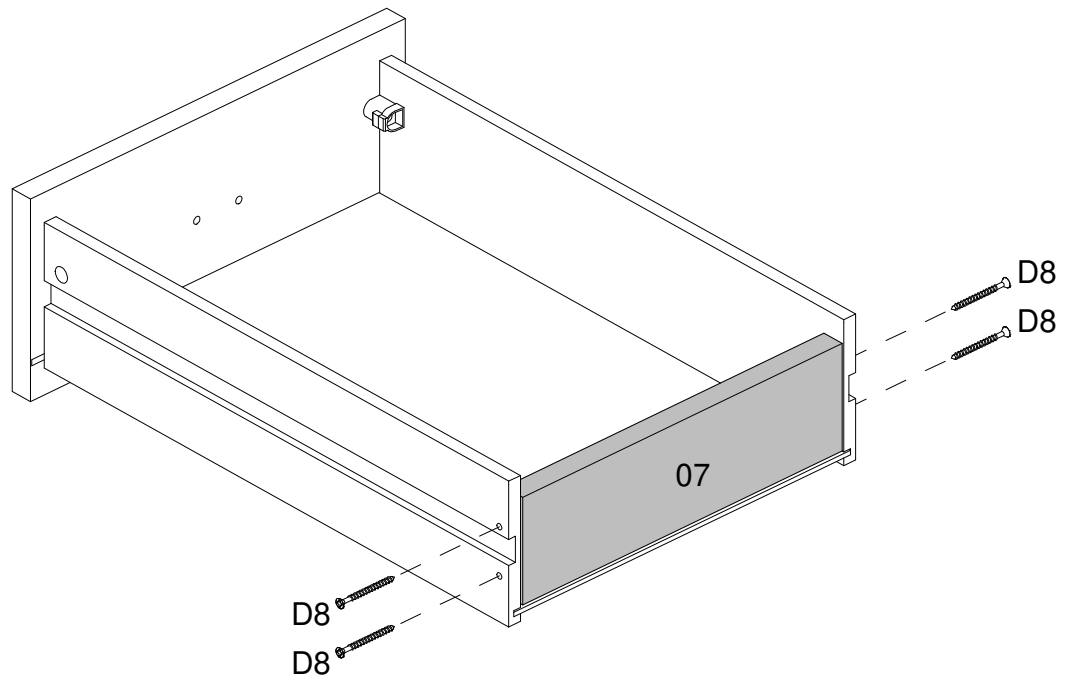



12

THE UNDERSIDE OF THE DRAWER  
LADO INFERIOR DA GAVETA  
PARTE INFERIOR DEL CAJÓN

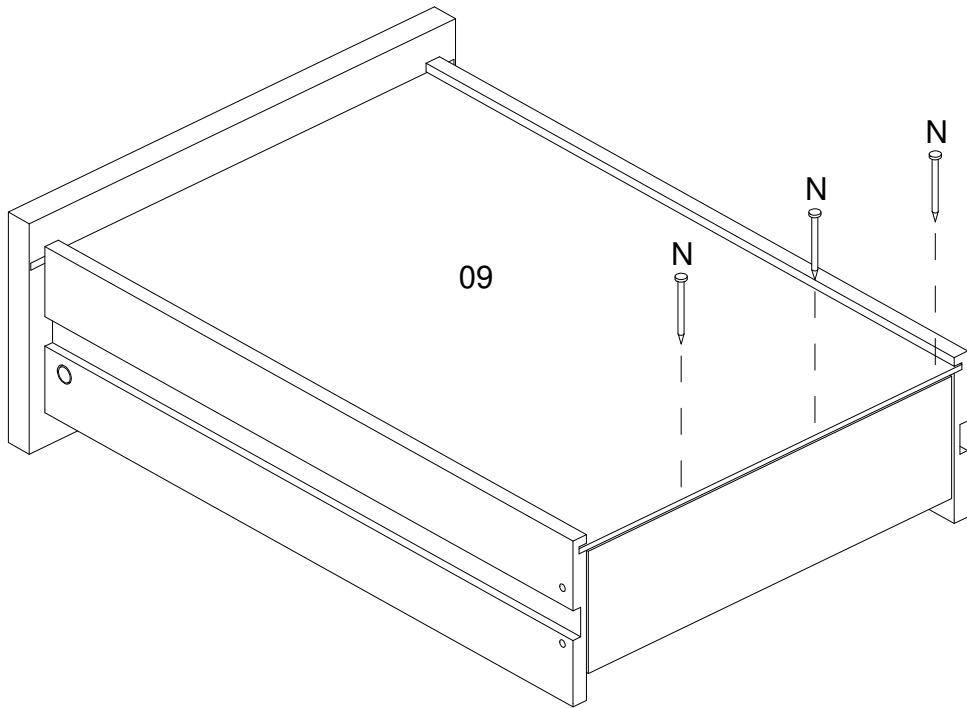

13

