

# ASSEMBLY INSTRUCTIONS MANUAL DE MONTAGEM / INSTRUCCIONES DE ARMADO

Malta office table - 2 drawers  
Mesa Malta - 2 gavetas  
Escritorio Malta - 2 cajones

Reference  
Referência  
Referencia **1171**

Revise  
Revisão  
Revisión **16**

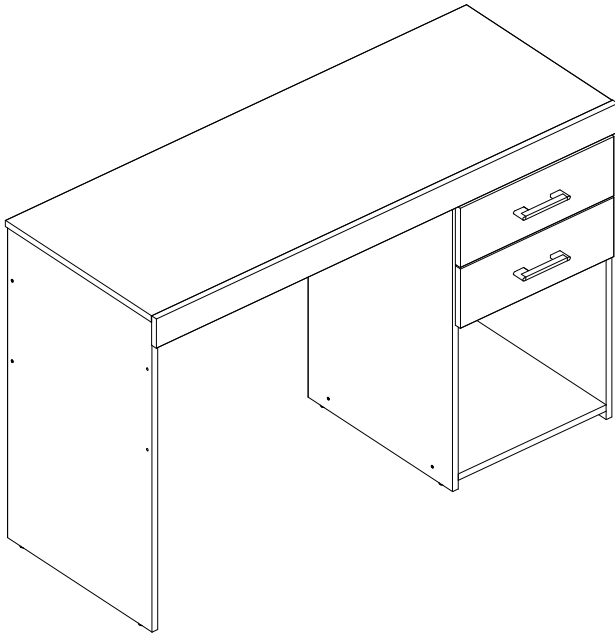

**NOTES:** THIS PRODUCT CAN BE ASSEMBLY WITH THE DRAWERS TO YOUR RIGHT OR LEFT.  
**NOTAS:** ESSE PRODUTO PODE SER MONTADO COM AS GAVETAS PARA SUA DIREITA OU ESQUERDA.  
**NOTAS:** ESTE PRODUCTO PUEDE SER ARMADO CON CAJONES A LA DERECHA O IZQUIERDA.

## YOU WILL NEED / VOCÊ VAI PRECISAR DE / USTED NECESITARÁ

### Tools not supplied / Ferramentas não fornecidas / Herramientas no incluidas

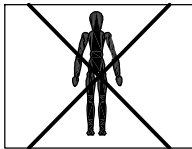

1 Person  
1 Pessoa  
1 Persona

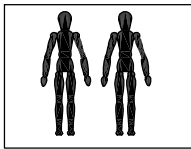

2 People  
2 Pessoas  
2 Personas

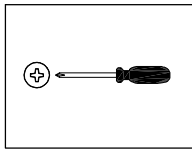

Screwdriver Phillips  
Chave Phillips  
Destornillador cruz

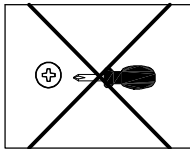

Small screwdriver Phillips  
Chave Phillips Menor  
Destornillador cruz menor

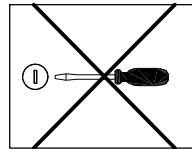

Screwdriver slotted  
Chave fenda  
Destornillador plano

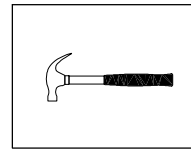

Hammer  
Martelo  
Martillo

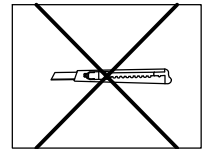

Stylet  
Estilete  
Estilete



Drill machine  
Furadeira  
Taladro

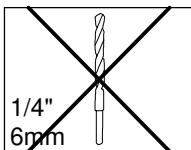

Drill bit  
Broca  
Taladro

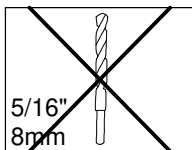

Drill bit  
Broca  
Taladro

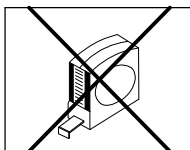

Measuring tape  
Trena  
Cinta de medición

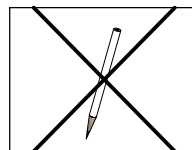

Pencil  
Lápis  
Lápis

**NOTES:** The separation of the accessories before you start the assembly will facilitate the same. In case of doubt on the size of the screws and bolts, use the ruler to bottom of page 3.

**NOTAS:** A separação dos acessórios antes de iniciar a montagem facilitará a mesma. Em caso de dúvida no tamanho dos parafusos e cavilhas, utilize a régua ao final da página 3.

**NOTAS:** La separación de los accesorios antes de comenzar el armado facilitará el mismo. En caso de duda sobre el tamaño de los tornillos y taquetes, utilice la regla al pie de página 3.

MAXIMUM RECOMMENDED WEIGHT  
BEING THIS EVENLY DISTRIBUTED

PESO MÁXIMO RECOMENDADO SENDO  
ESTE DISTRIBUÍDO UNIFORMEMENTE

PESO MÁXIMO RECOMENDADO SIENDO  
ESTE UNIFORMEMENTE DISTRIBUIDO

	LB	KG
<b>A</b>	55	25
<b>B</b>	11	5
<b>C</b>	22	10

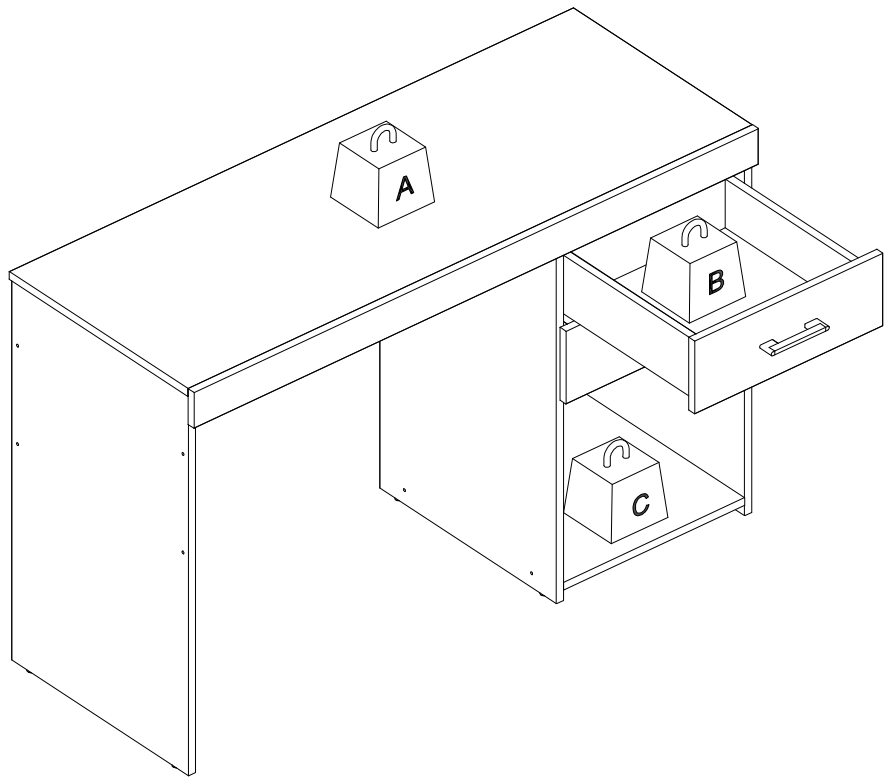





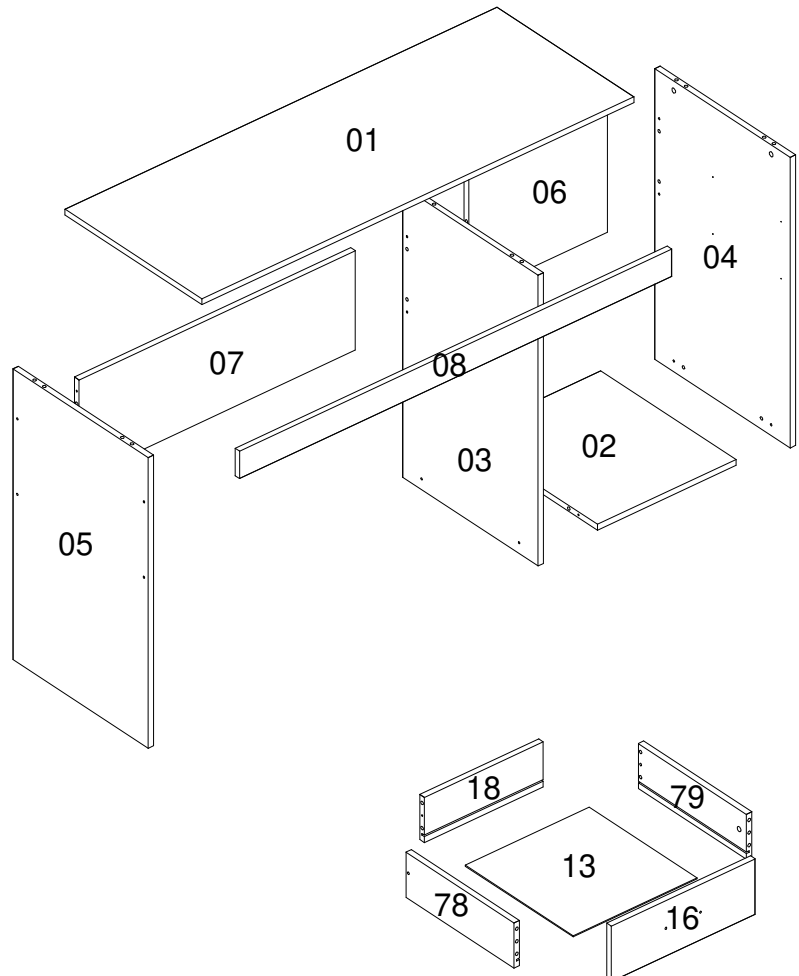





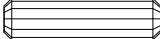

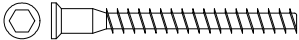



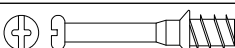

Nº	Measures Inches	Medidas cm	Qty./Qtd.
01	47" 1/4 x 17" 3/4 x 5/8	120 x 45 x 1,5	1
02	15" 1/8 x 17" 1/2 x 5/8	38,5 x 44,5 x 1,5	1
03	29" 1/8 x 17" 1/2 x 5/8	74 x 44,5 x 1,5	1
04	29" 1/8 x 17" 1/2 x 5/8	74 x 44,5 x 1,5	1
05	29" 1/8 x 17" 1/2 x 5/8	74 x 44,5 x 1,5	1
06	15" 1/8 x 13" 3/8 x 5/8	38,5 x 34,1 x 1,5	1
07	30" 1/8 x 10" x 5/8	76,7 x 25,4 x 1,5	1
08	47" 1/4 x 2" 3/4 x 5/8	120 x 7 x 1,5	1
13	13" 7/8 x 13" 1/2 x 1/8	35,4 x 34,4 x 0,3	2
16	15" 3/4 x 5" 5/8 x 5/8	40 x 14,2 x 1,5	2
18	13" x 4" 1/2 x 5/8	33 x 11,5 x 1,5	2
78	14" x 4" 1/2 x 5/8	35,5 x 11,5 x 1,5	2
79	14" x 4" 1/2 x 5/8	35,5 x 11,5 x 1,5	2

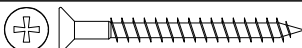
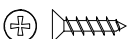
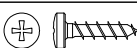
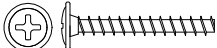
**PARTS IDENTIFICATION**  
**IDENTIFICAÇÃO DAS PEÇAS / IDENTIFICACIÓN DE LAS PIEZAS**

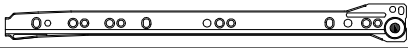
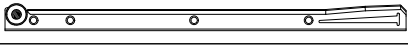

## IDENTIFICATION OF ACCESSORIES IDENTIFICAÇÃO DOS ACESSÓRIOS/ IDENTIFICACIÓN DE ACCESORIOS

A1		Glue / Cola / Pegamento	13 g	1
A2		Small plastic foot / Sapata redonda / Pie plástico	14 mm	6
B5		Metalic angle plates / Cantoneira de metal / Suporte de metal	46 mm	1
E		Wooden dowel / Cavilha / Taquete	8x30 mm	30
F		Wooden dowel / Cavilha / Taquete	8x50 mm	2
G		Structural screw / Parafuso estrutural / Tornillo estructural	5,0x50 mm	8
H		Allen key / Chave allen / Liave allen	3 mm	1
H9		Plastic hole plugs / Tapa furo plástico / Tapones plásticos	5 mm	6
I		Structural screw cover/Tampa parafuso estrutural/Tapa tornillo estructural	-	6
J		Simple minifix screw / Haste minifix simples / Tornillo minifix simple	-	13
L		Drum lock / Tambor minifix / Tambor minifix	12 mm	13
K4		Fixing bracket of frames / Suporte fixação vistas / Soporte de fijación molduras	-	3
M		Bore patch adhesive / Tapa furo adesivo / Tapones adhesivo	-	5
N		Nail / Prego / Clavo	10x10	6
O		Flat head screw / Parafuso chato / Tornillo de cabeza plana	4,5x45 mm	4
P5		Flat head screw / Parafuso chato especial / Tornillo de cabeza plana	3,5x14 mm	16
S		Pan head screw / Parafuso panela / Tornillo de pan	3,5x14 mm	10
T		Flanged head screw / Parafuso flangeado / Tornillo de cabeza flangeada	3,5x25 mm	4
VA		Metallic slide the left field / Corrediça lateral esquerda / Corredera lateral izquierda	350 mm	2
VB		Metallic slide the right field / Corrediça lateral direita / Corredera lateral derecha	350 mm	2
VC		Drawer slide left / Corrediça gaveta esquerda / Corredera izquierda cajón	350 mm	2
VD		Drawer slide right / Corrediça gaveta direita / Corredera derecha cajón	350 mm	2
V12		Handle/ Puxador Sevilha / Tirador	96 mm	2
Z		Plastic hole plugs / Tapa furo plástico / Tapones plásticos	8 mm	4



PRE-ASSEMBLE  
PRÉ-MONTAGE / PRE ARMADO

01

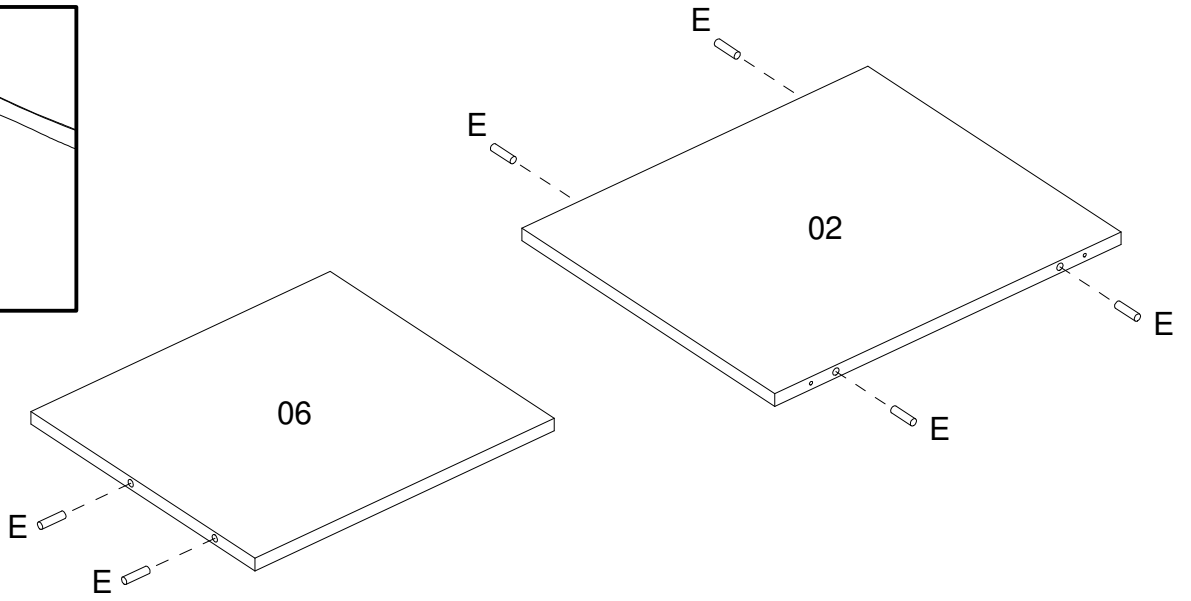
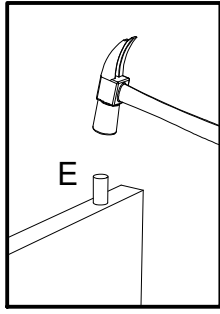

02

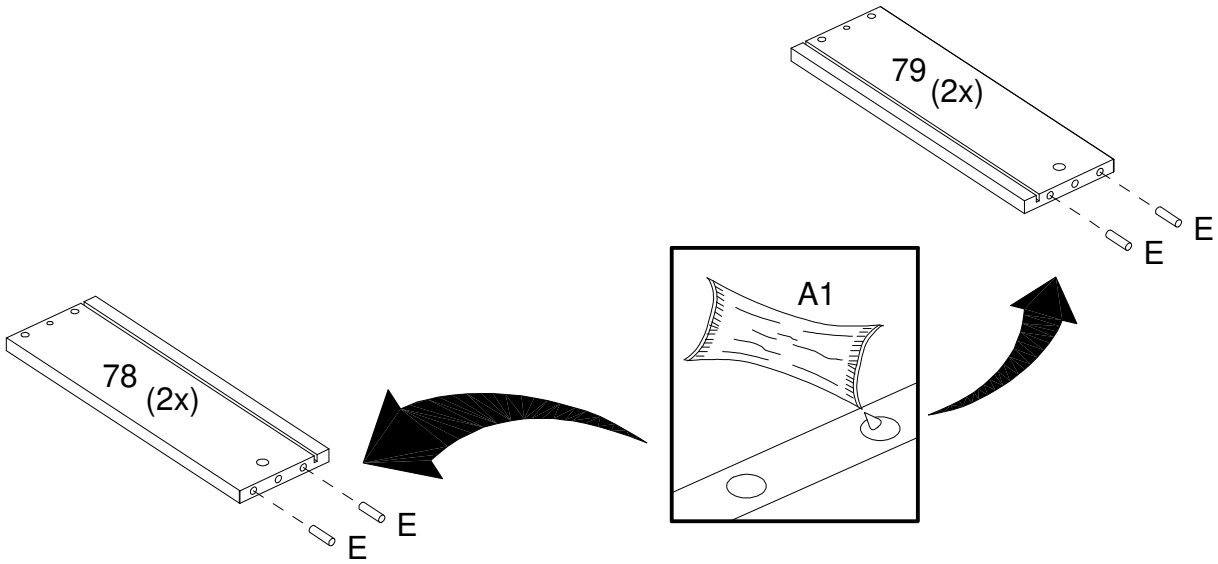

03

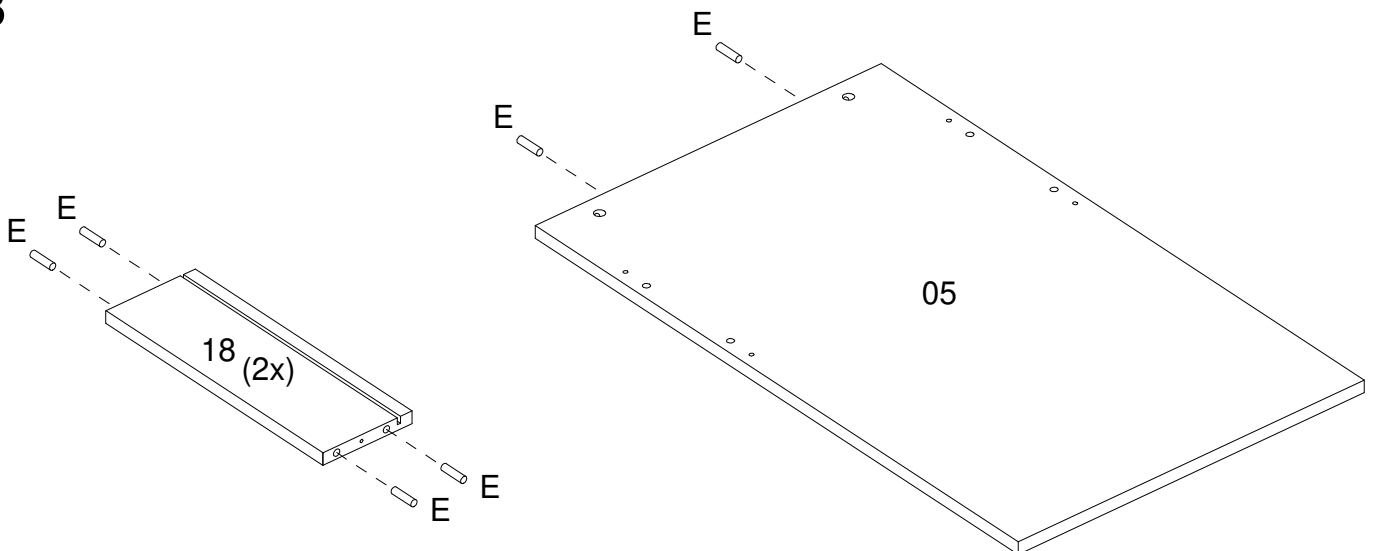

04

ATTENTION FOR POSITION  
ATENÇÃO PARA POSIÇÃO  
ATENCIÓN CON LA POSIÇÃO

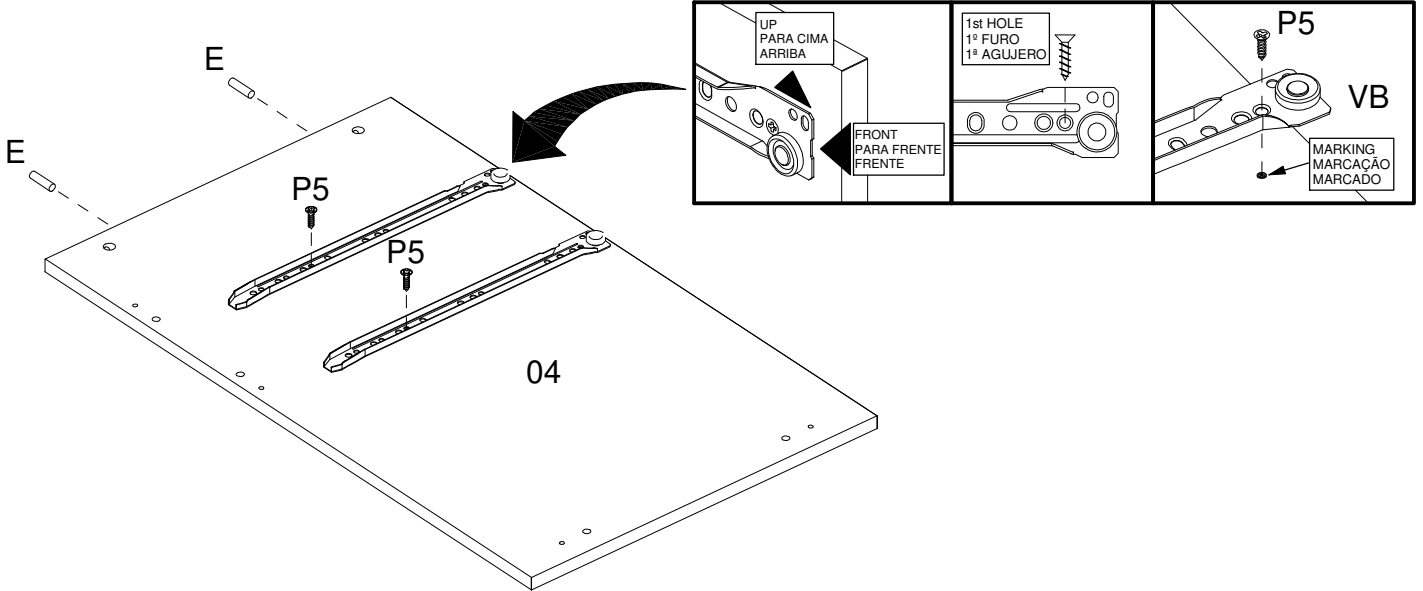

05

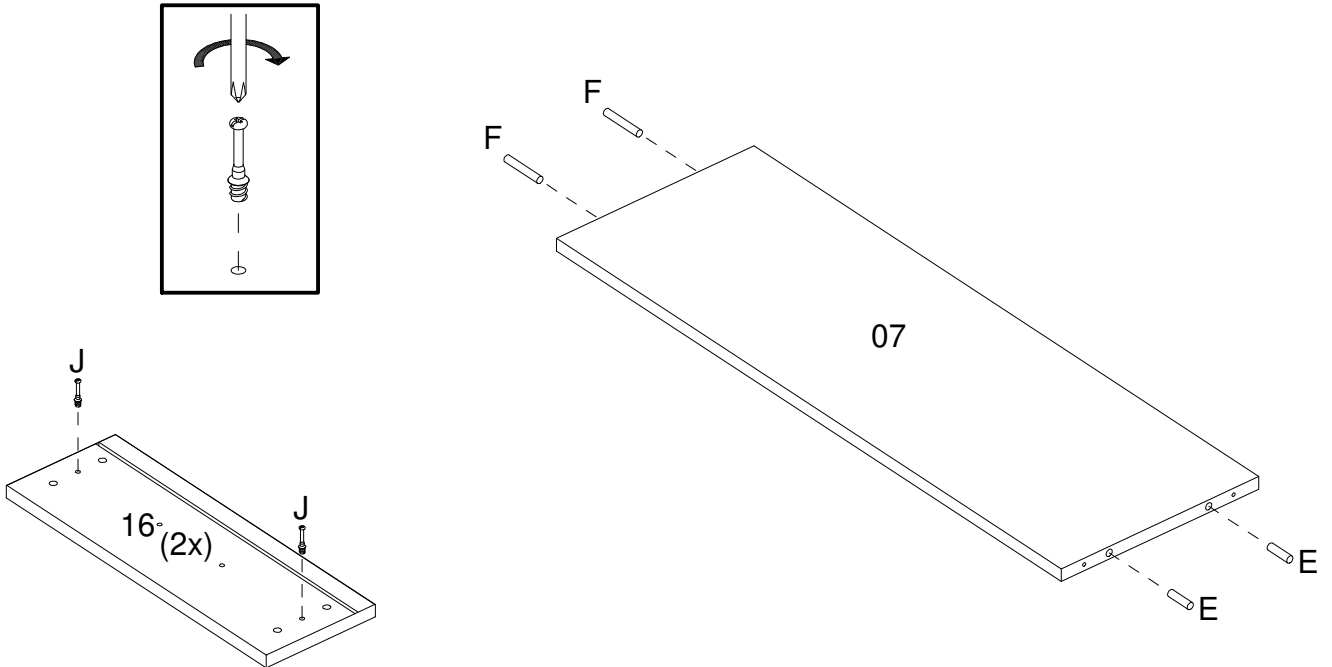

06

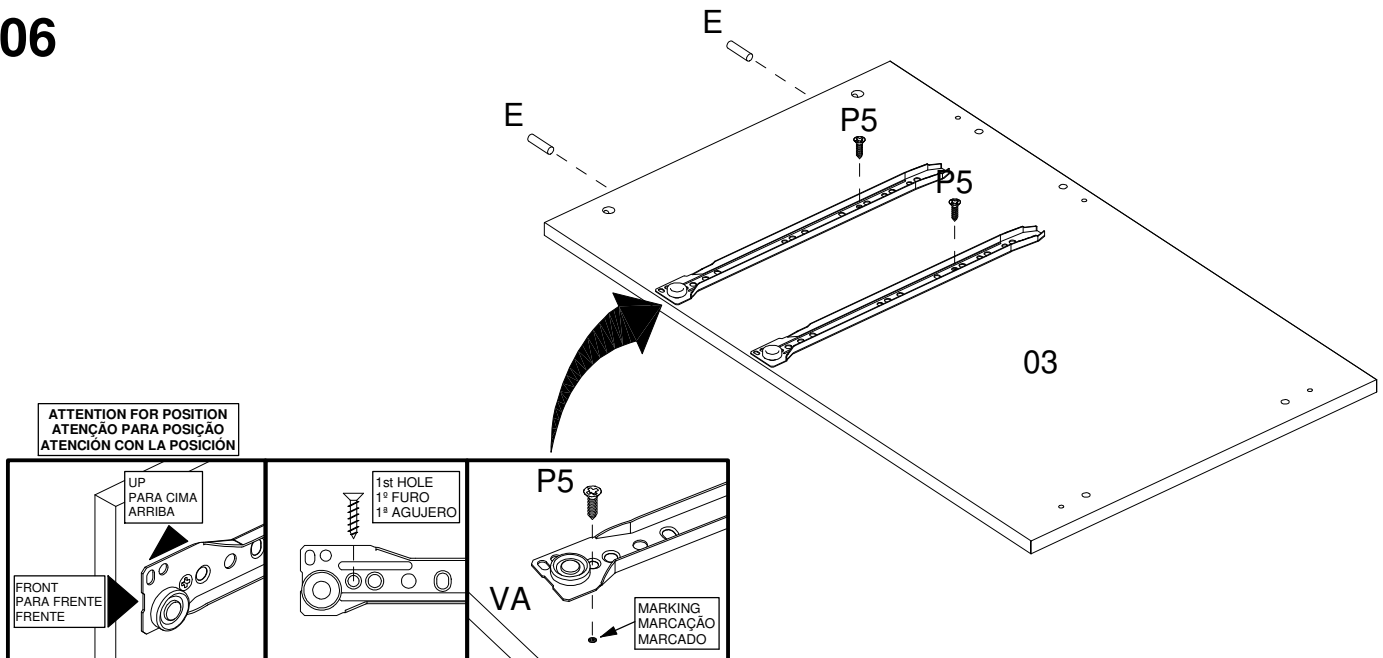

ASSEMBLY  
MONTAGEM / ARMADO

07

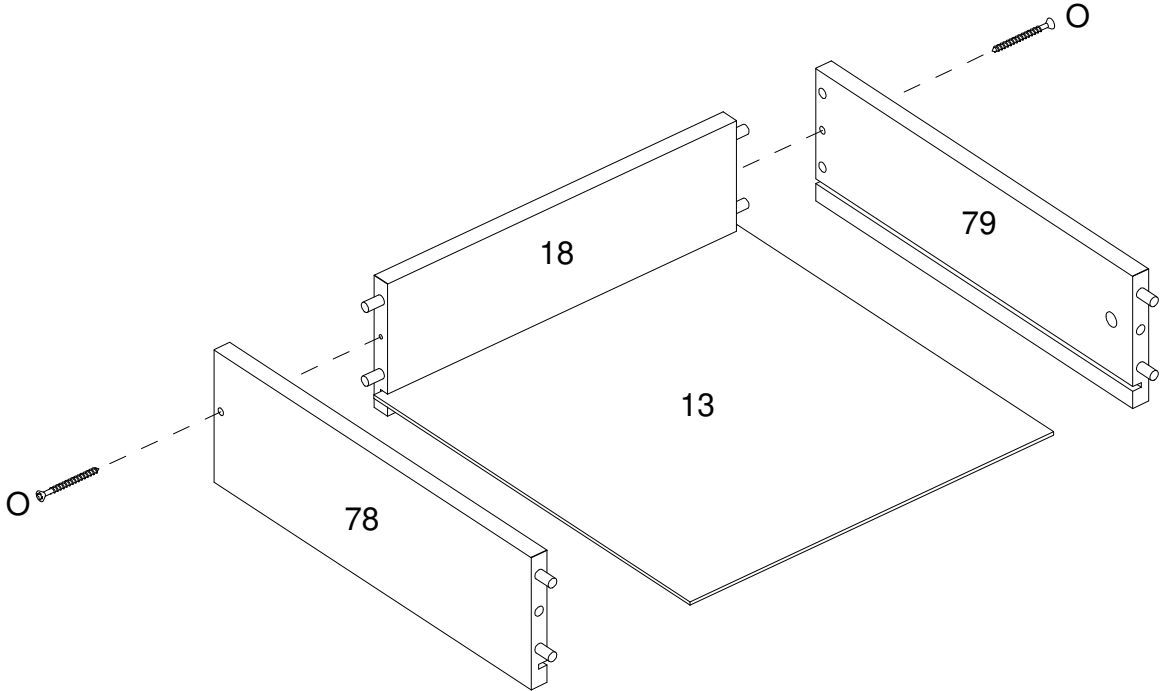

08

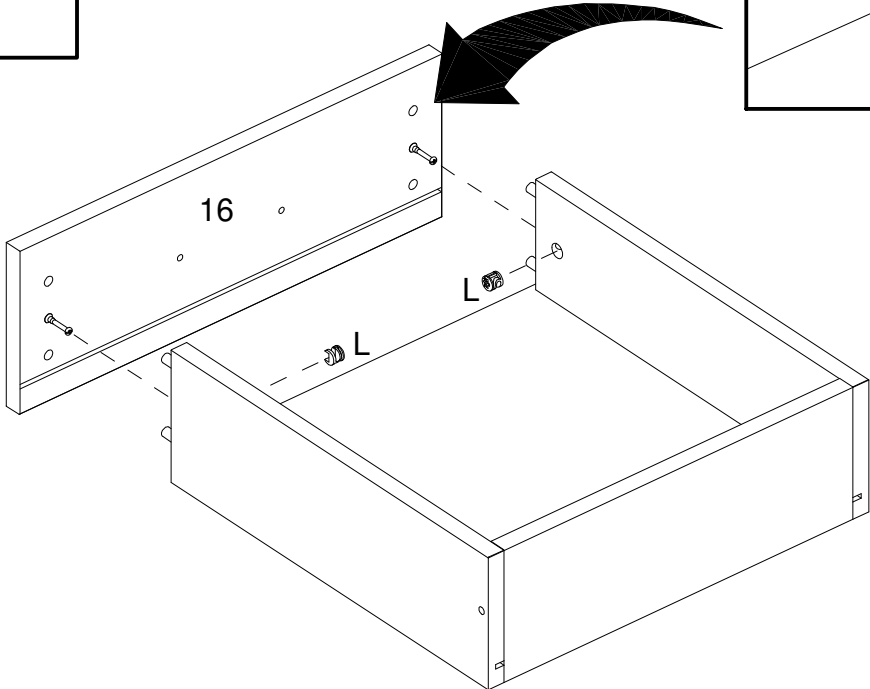
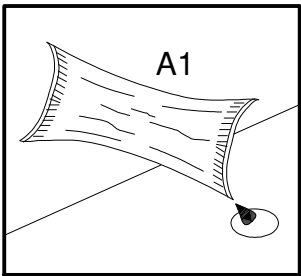
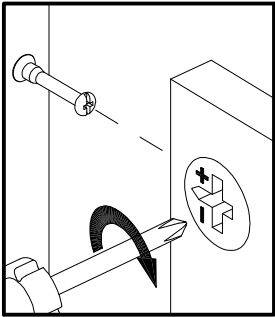

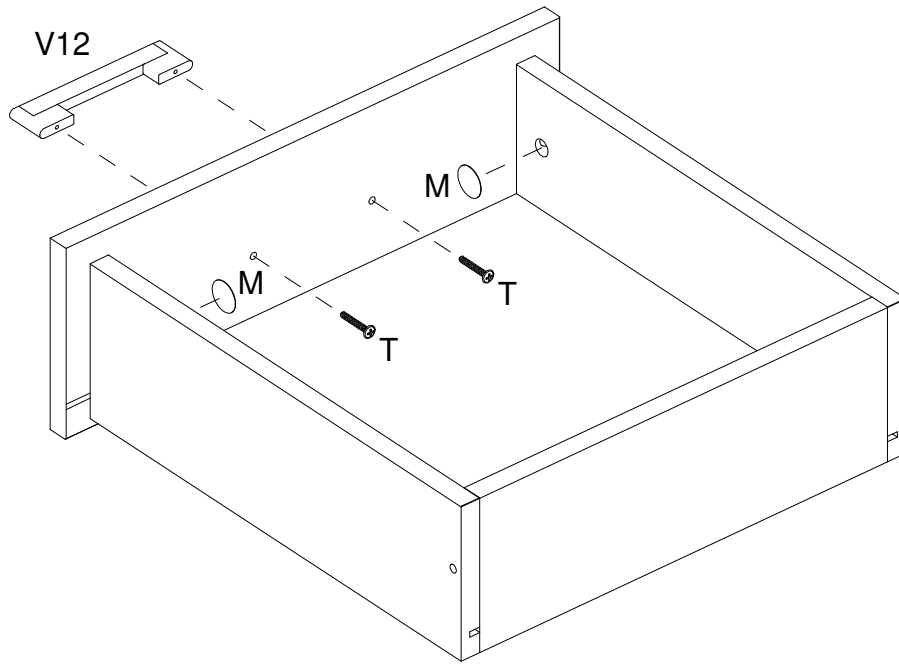

THE UNDERSIDE OF THE DRAWER  
 LADO INFERIOR DA GAVETA  
 PARTE INFERIOR DEL CAJÓN

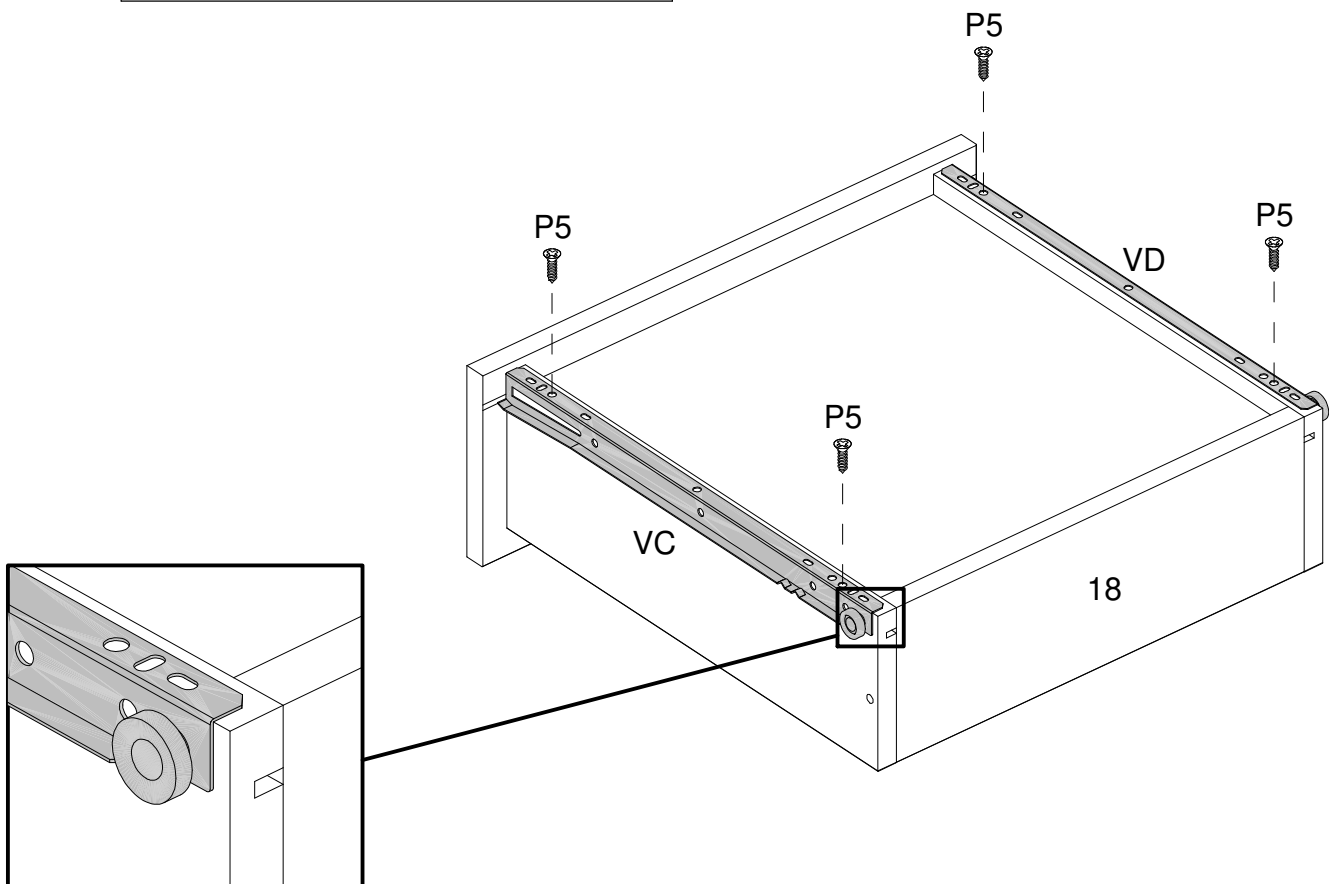

ASSEMBLY WITH DRAWERS FOR RIGHT  
MONTAGEM COM GAVETAS PARA A DIREITA / ARMADO CON LAS CAJONES PARA LA DERECHA

11

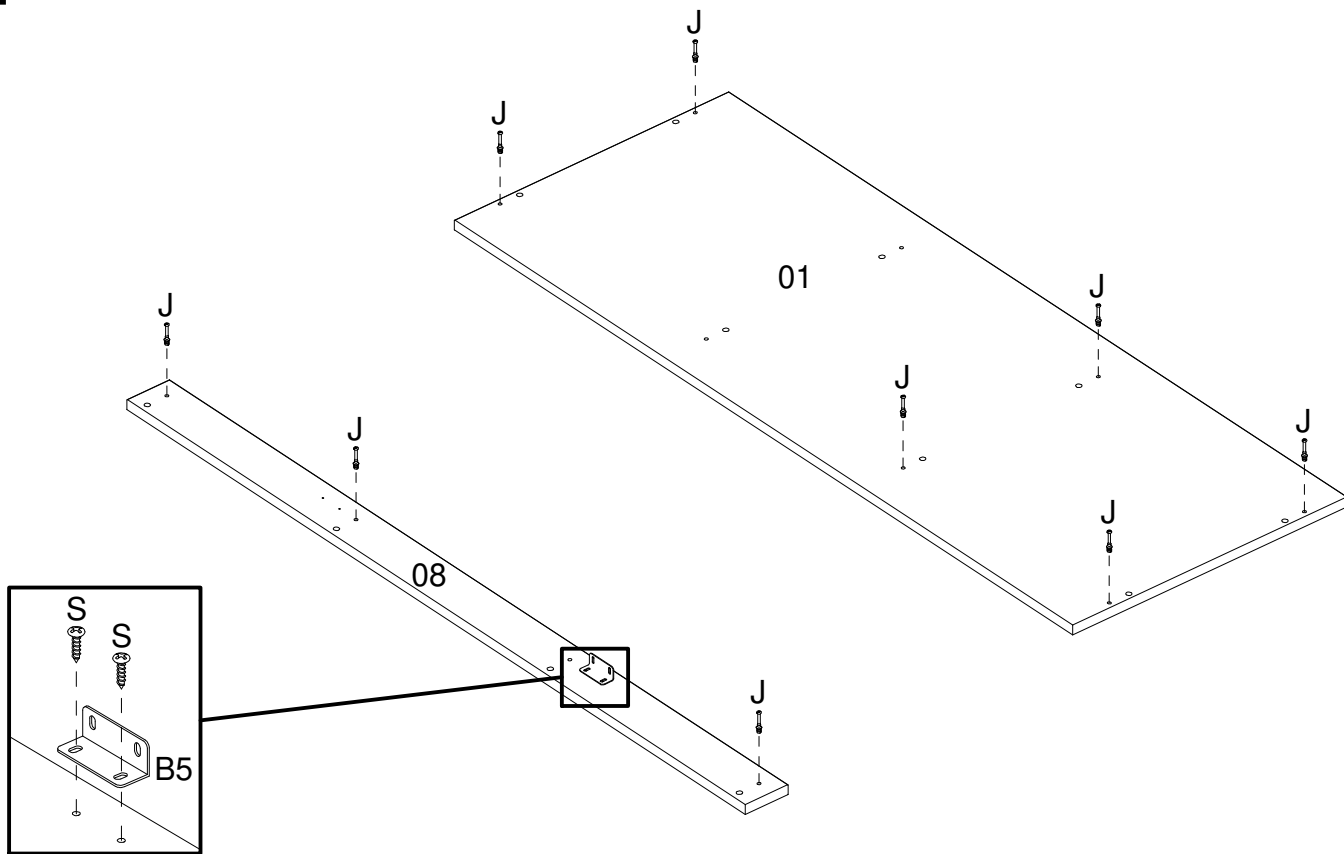

12

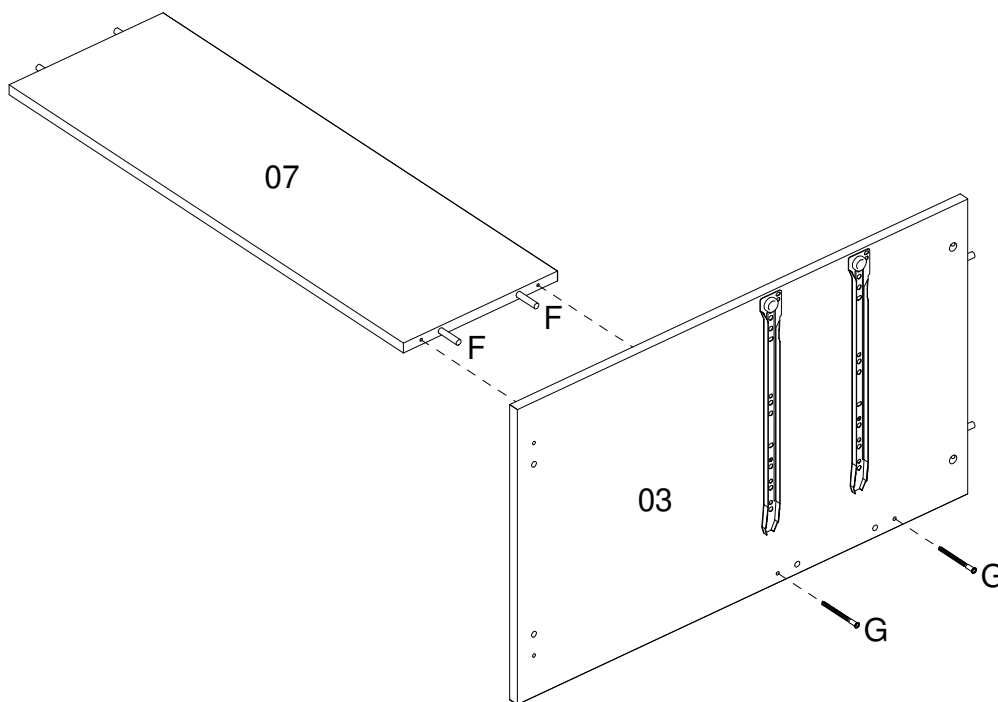
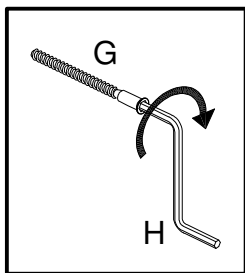



13

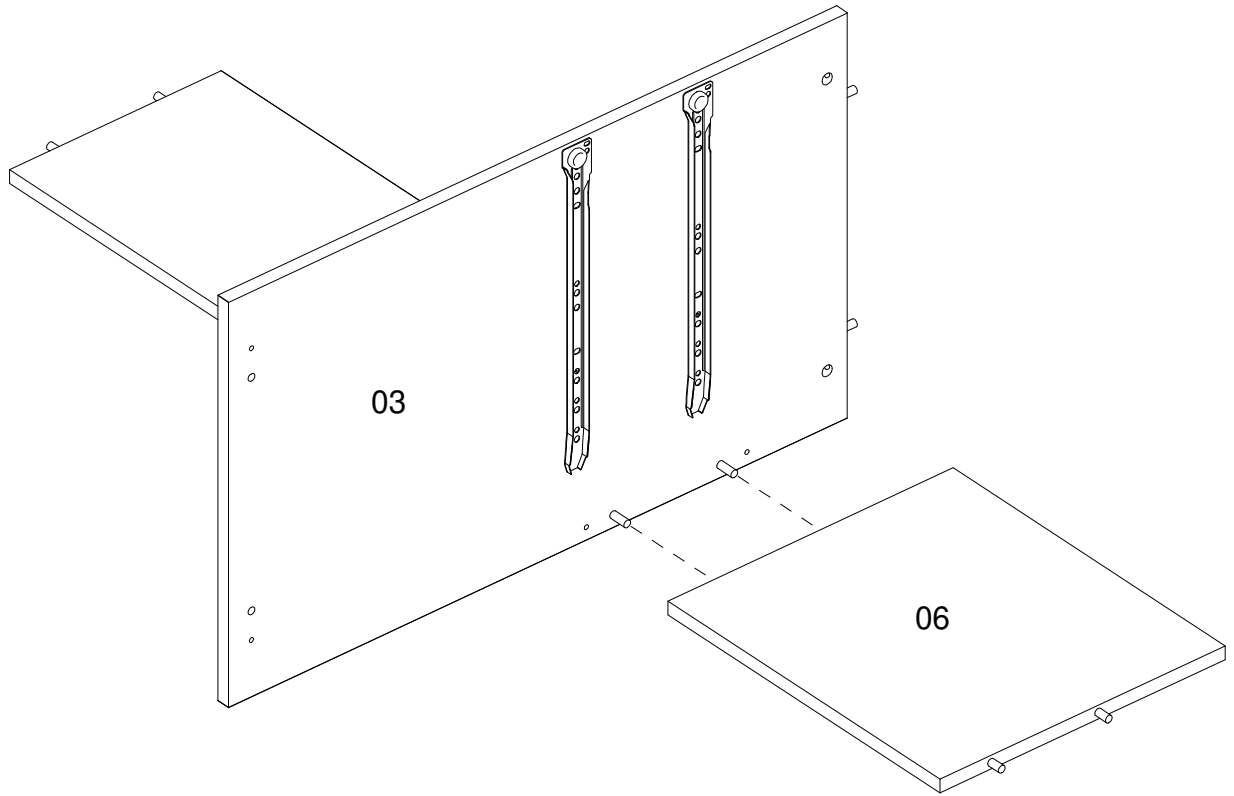

14

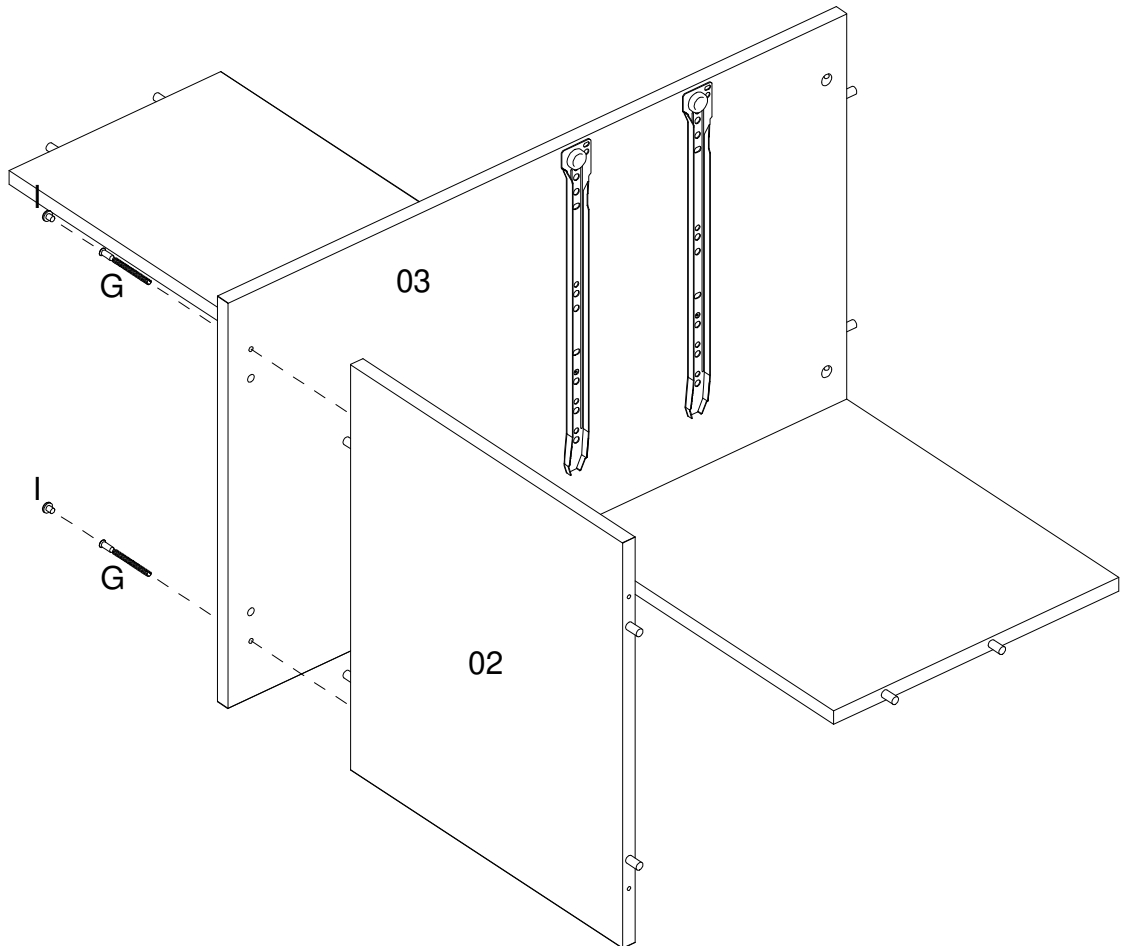

15

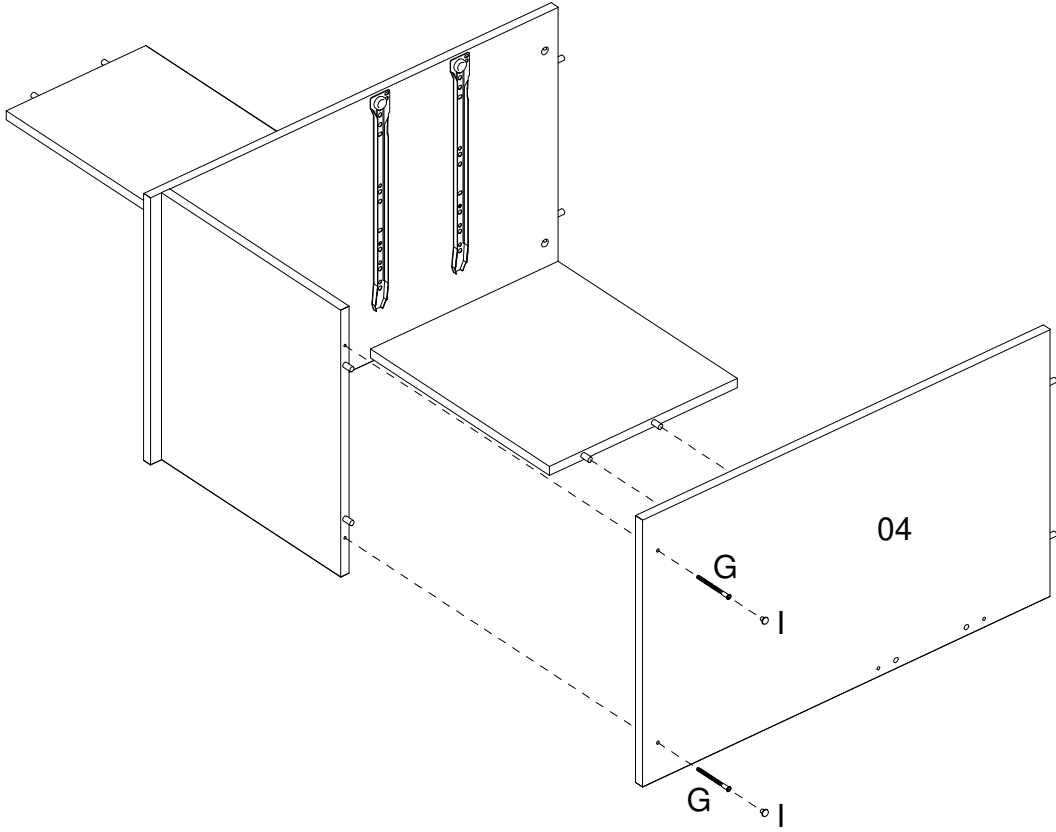

16

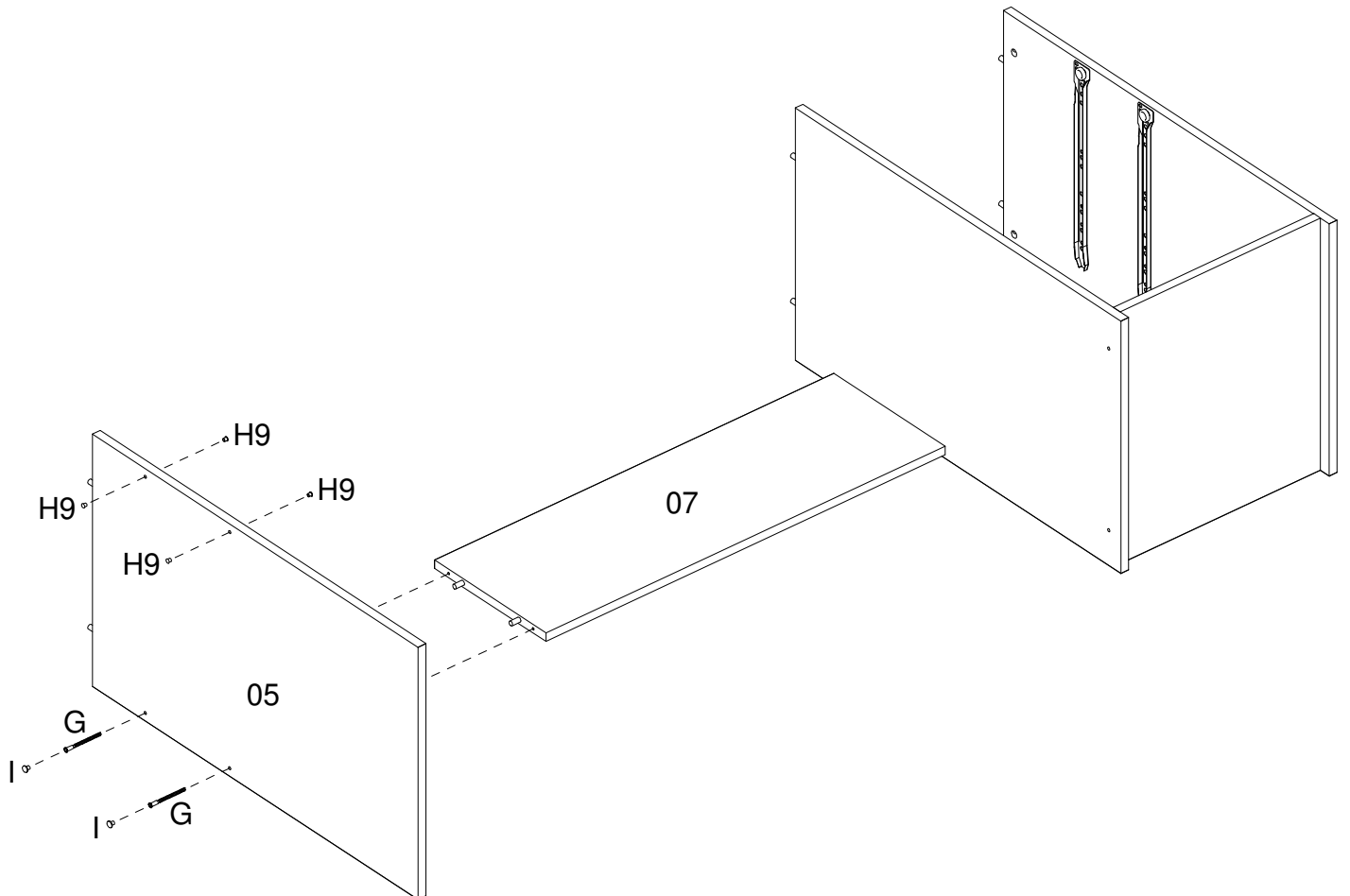

17

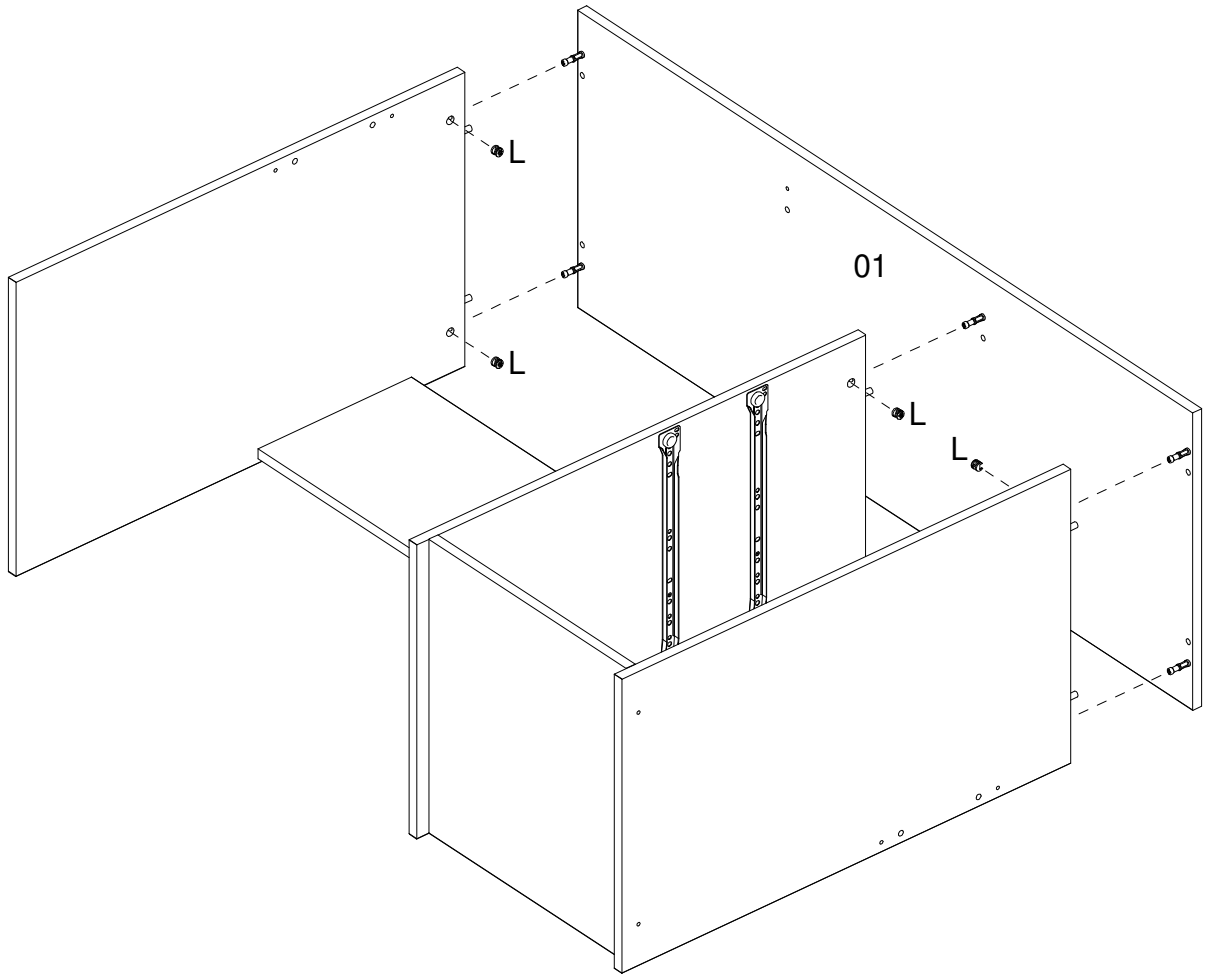

18

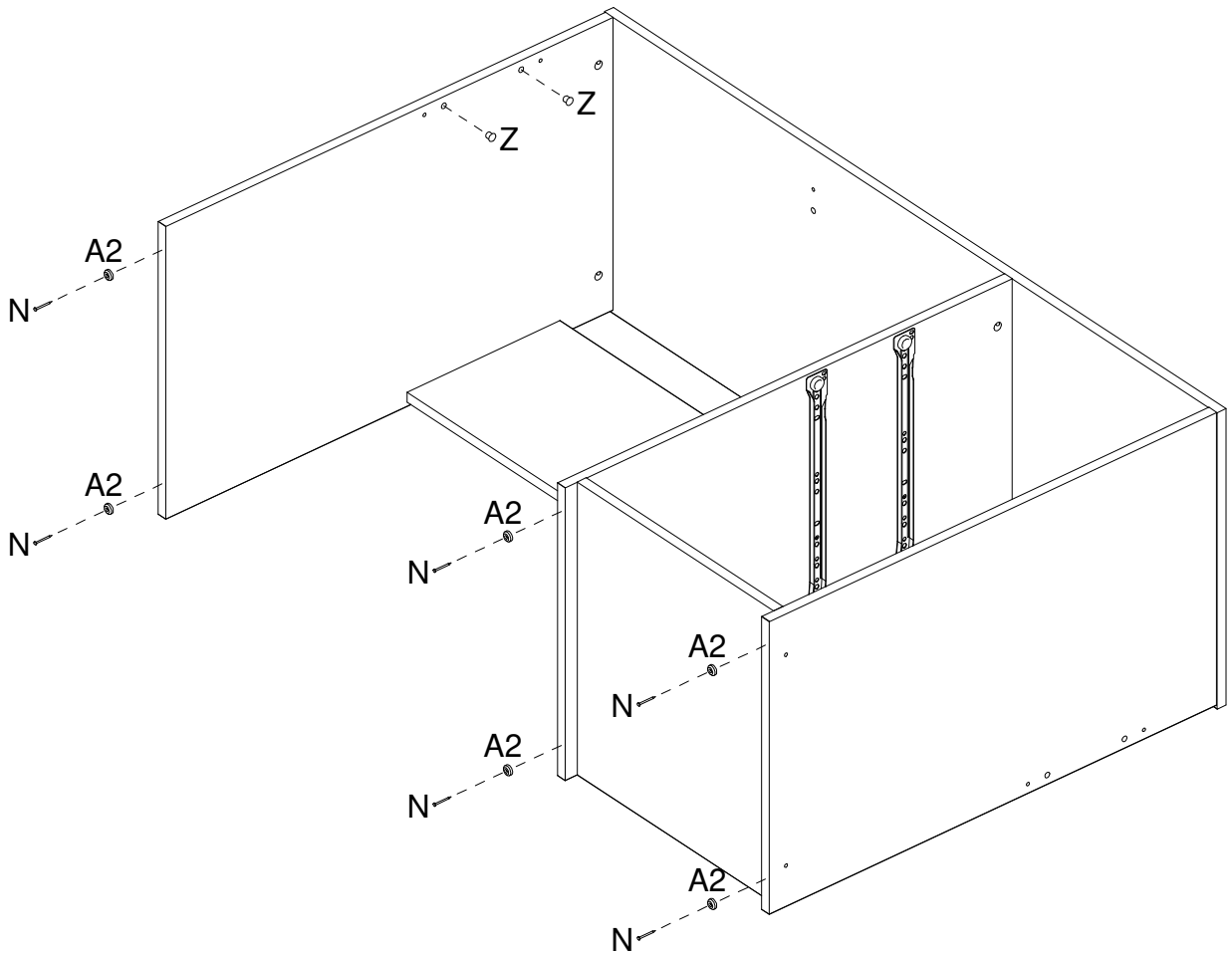

19

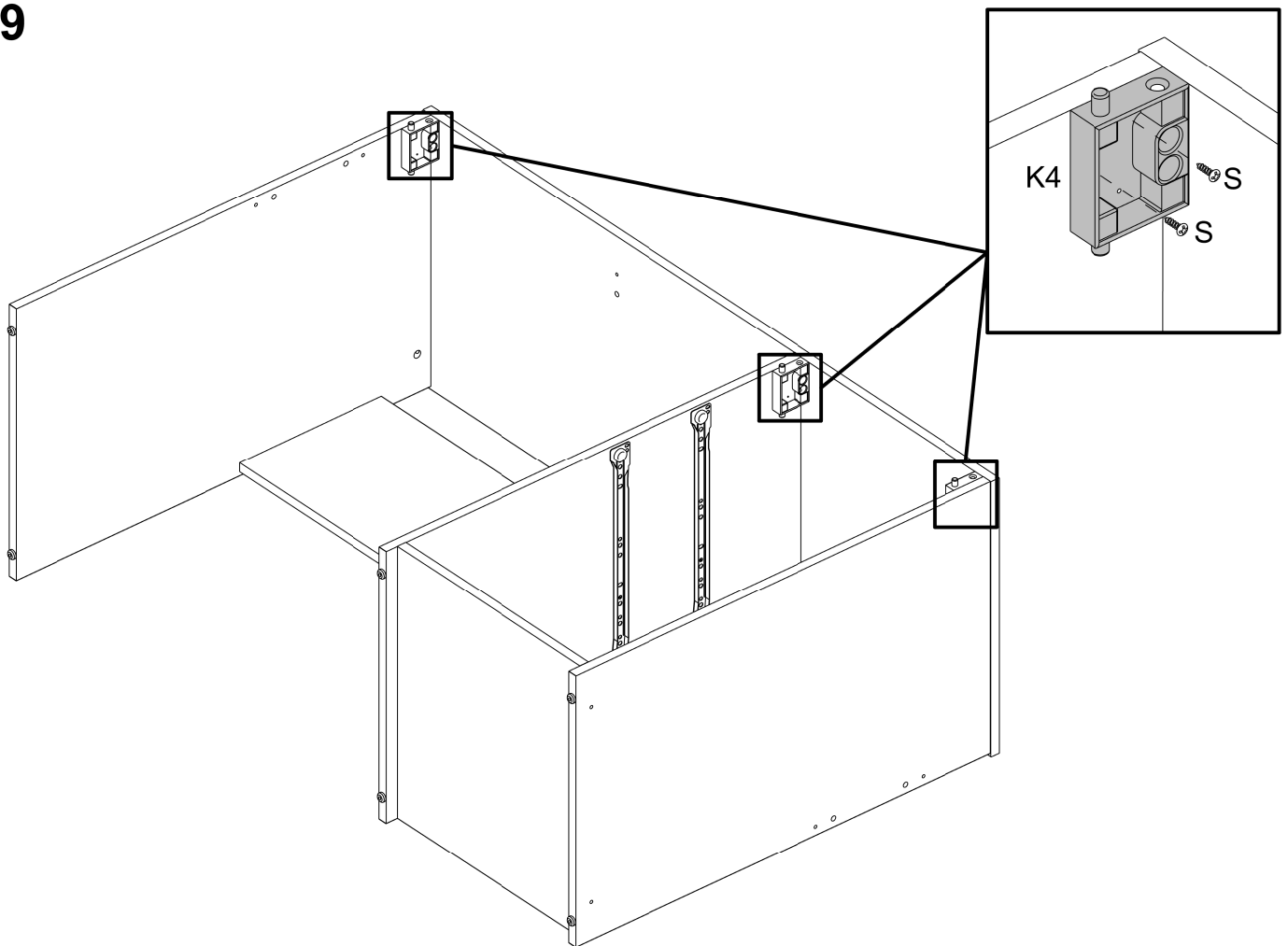

20

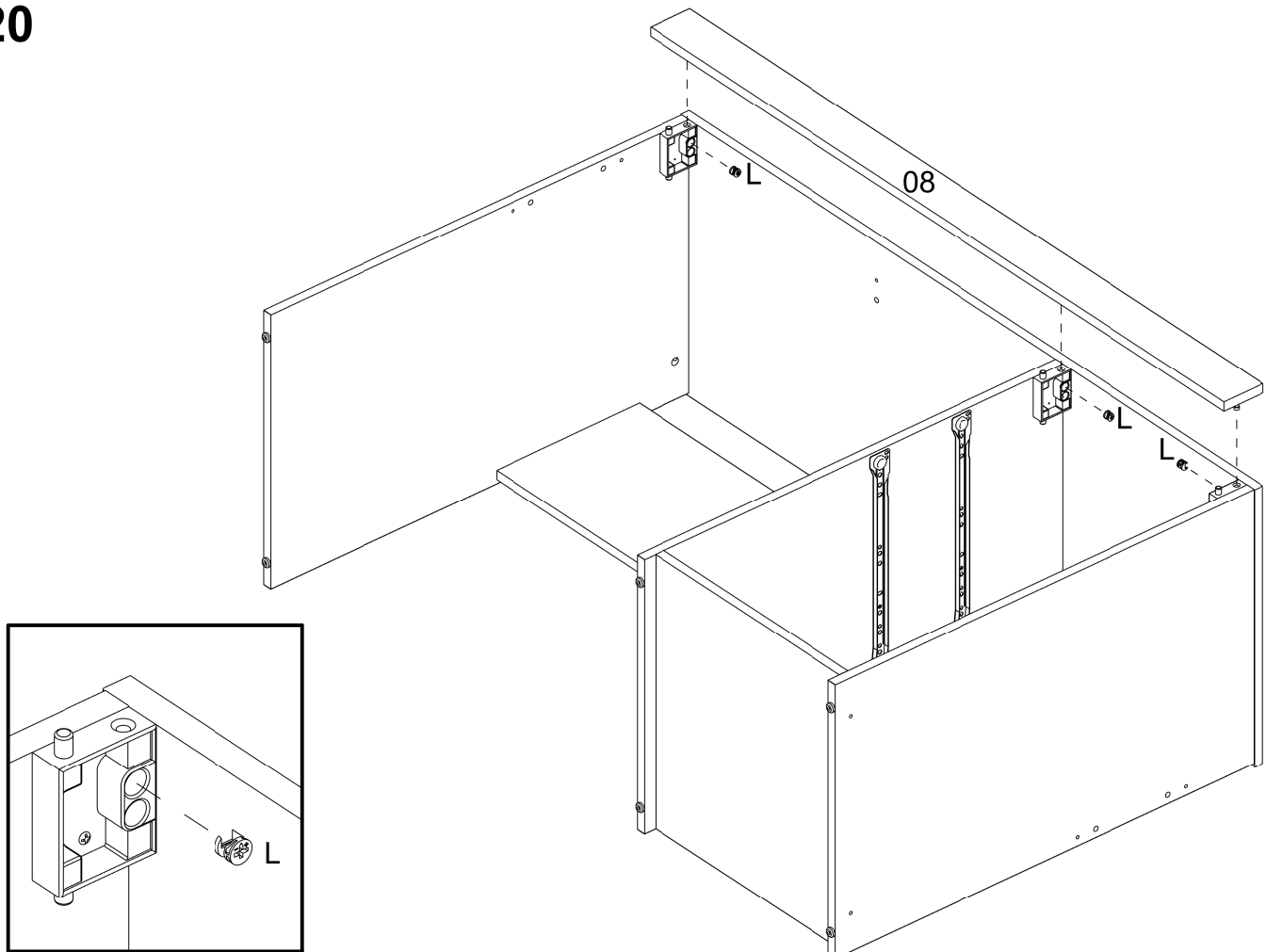

21

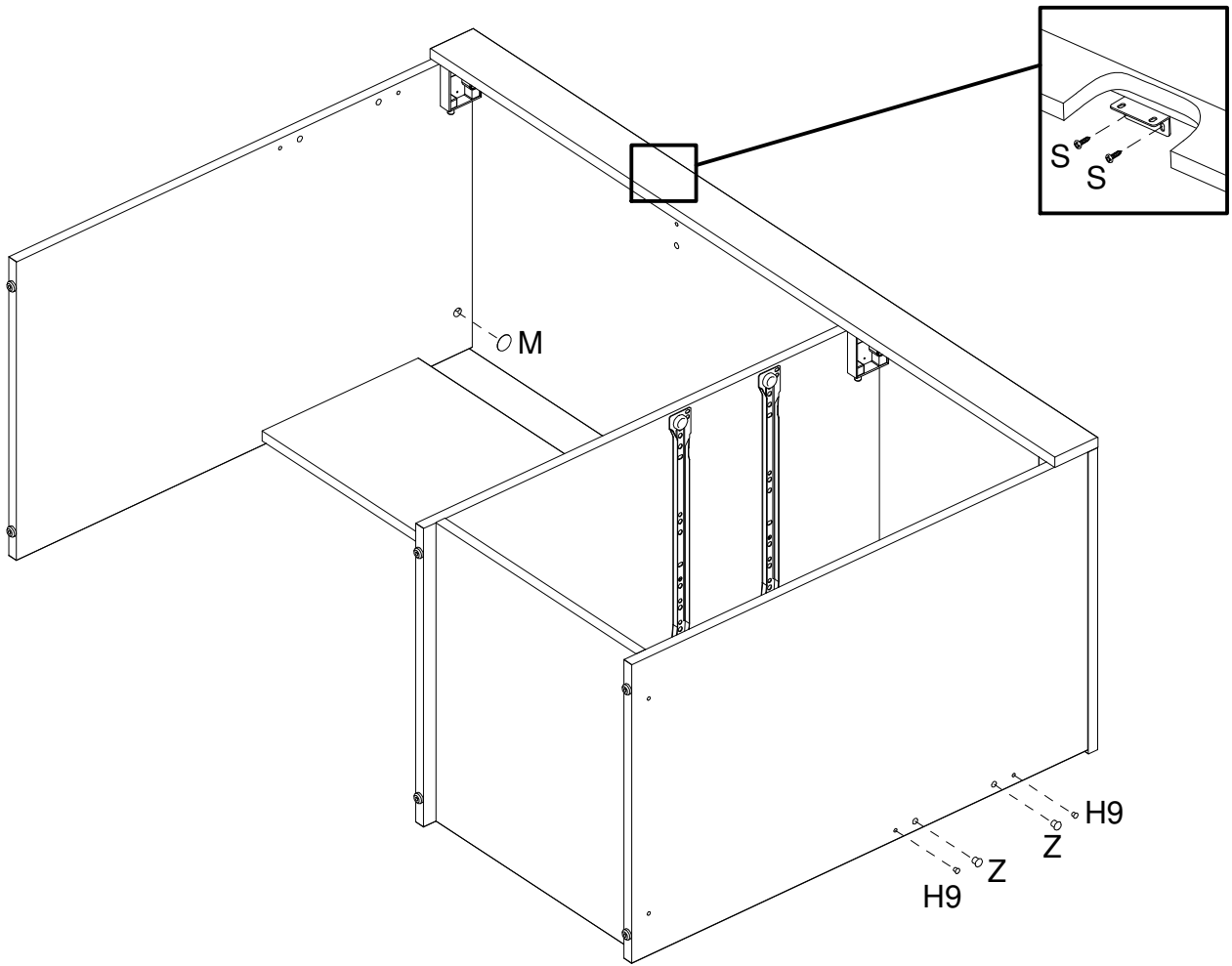

22

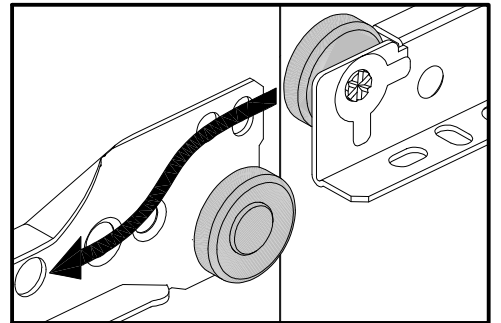
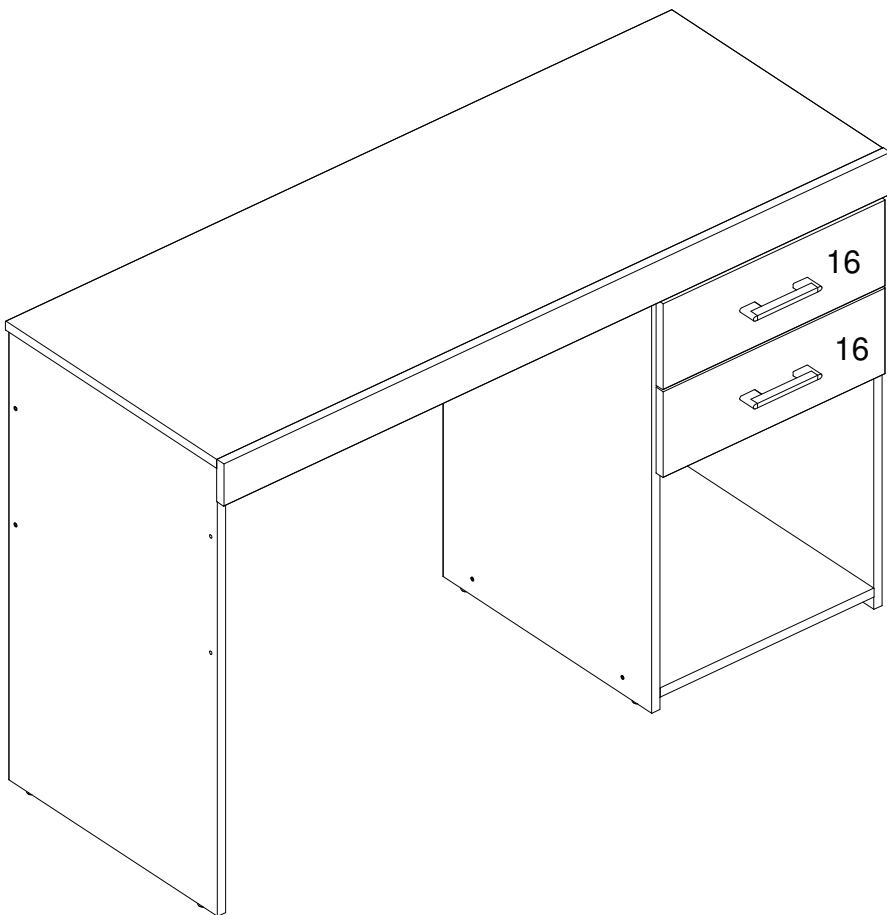

ASSEMBLY WITH DRAWERS FOR LEFT

MONTAGEM COM GAVETAS PARA A ESQUERDA / ARMADO CON LAS CAJONES PARA LA IZQUIERDA

23

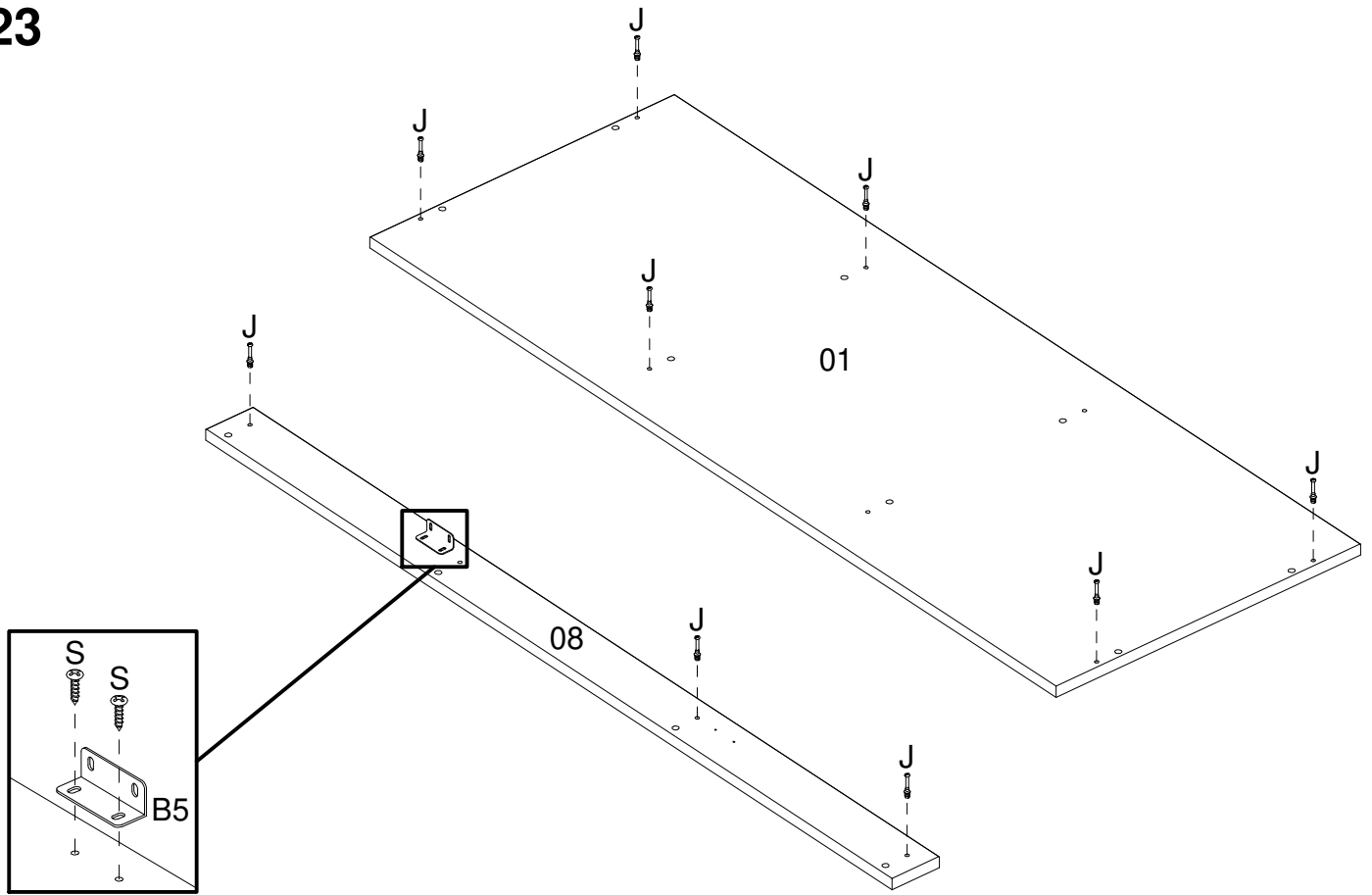

24

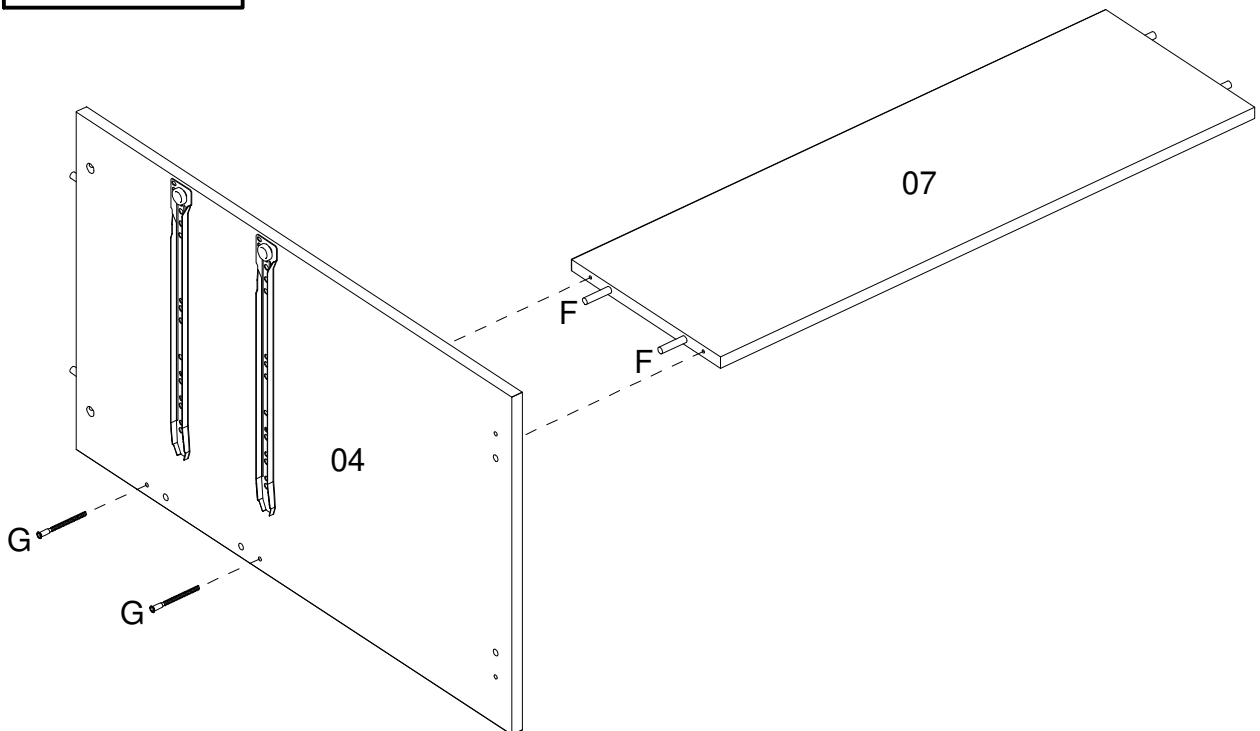
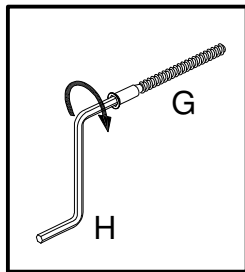

25

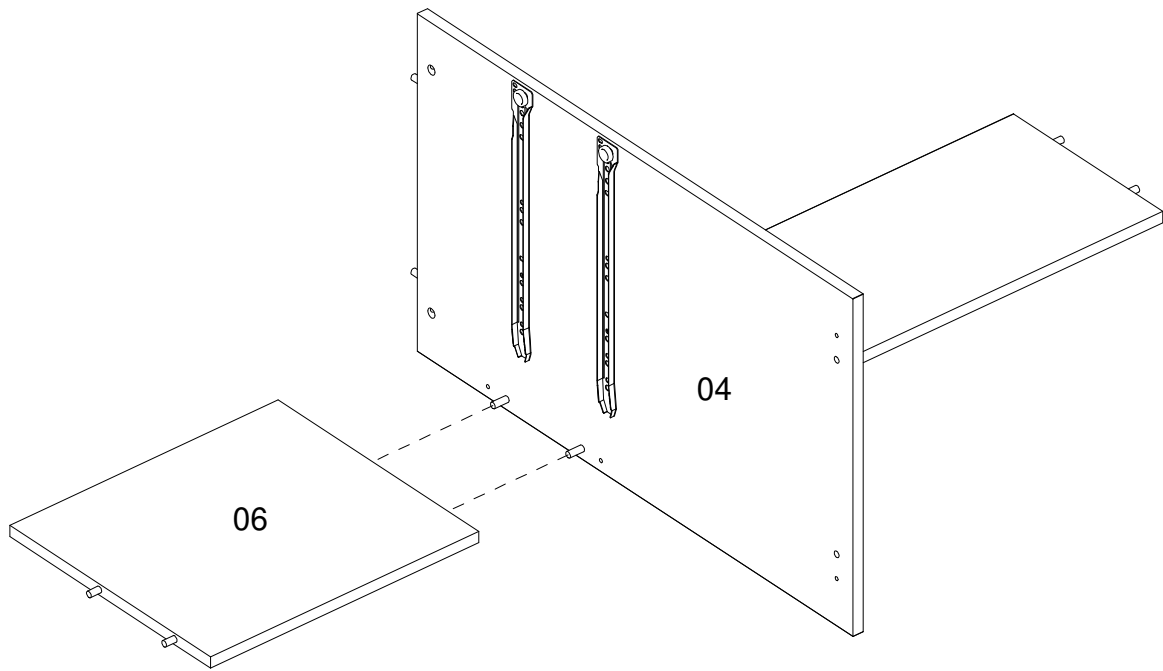

26

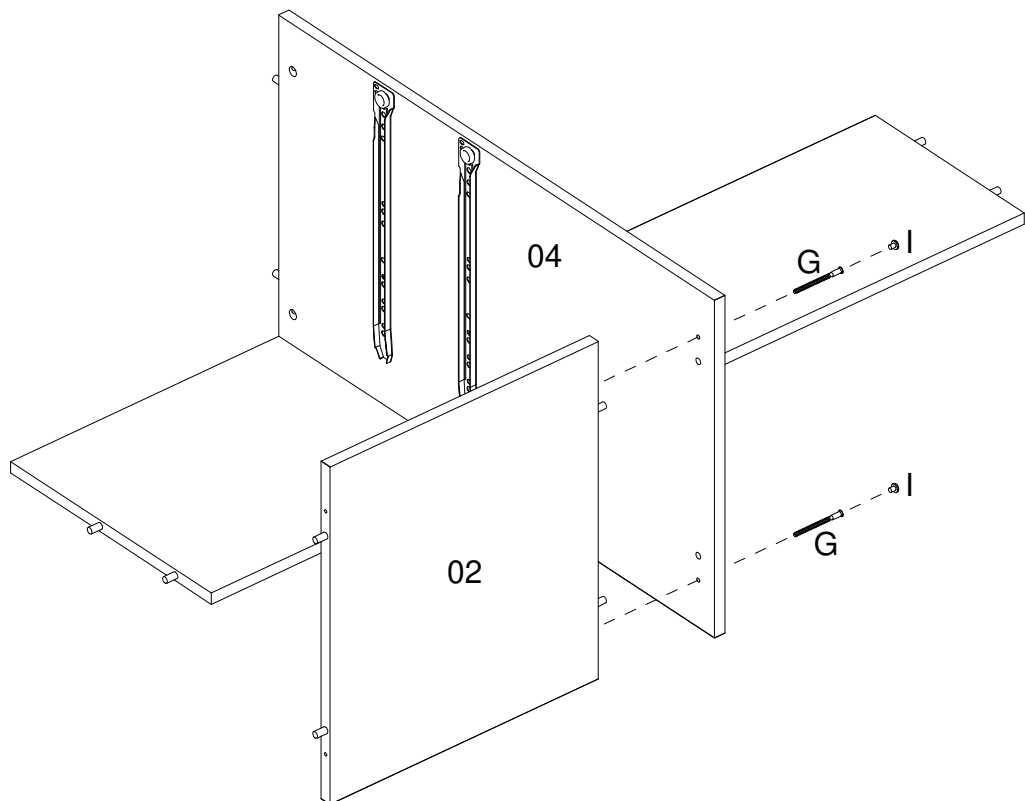

27

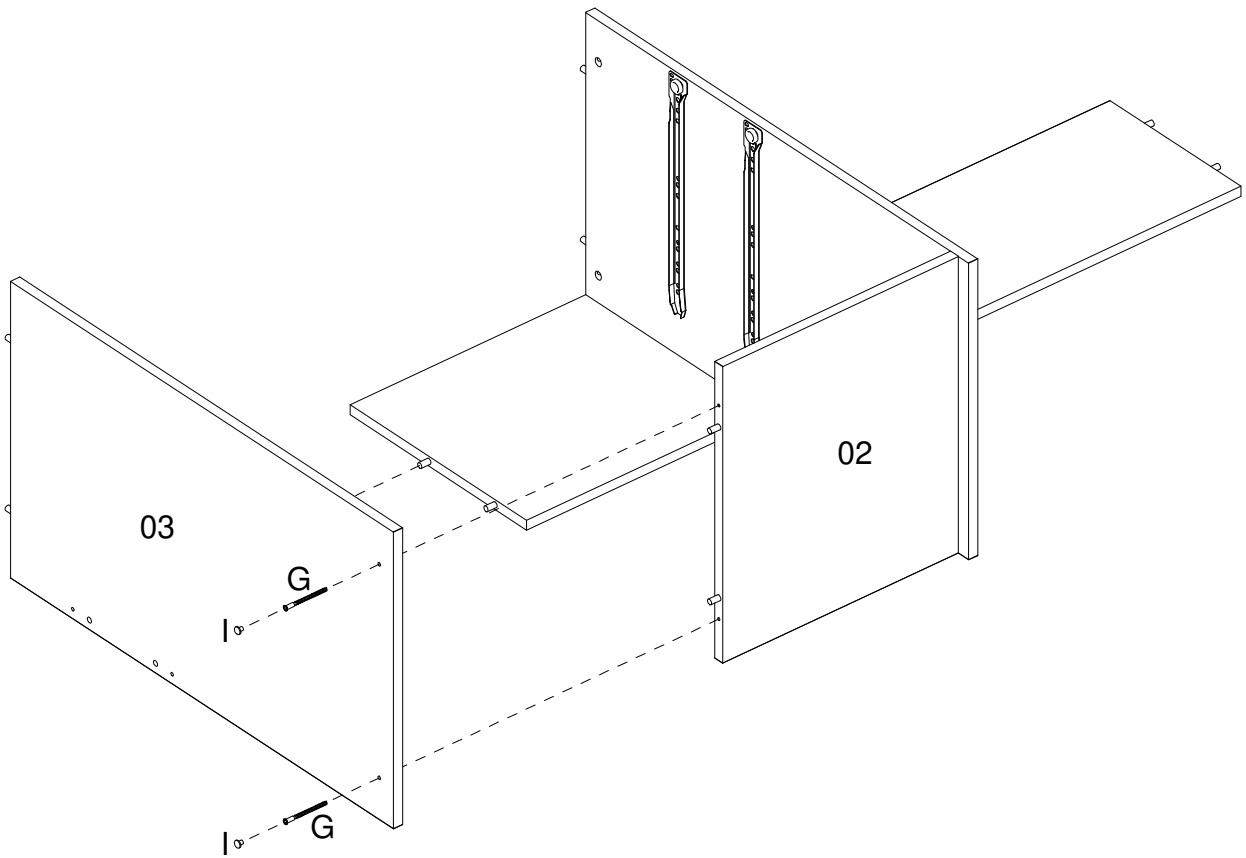

28

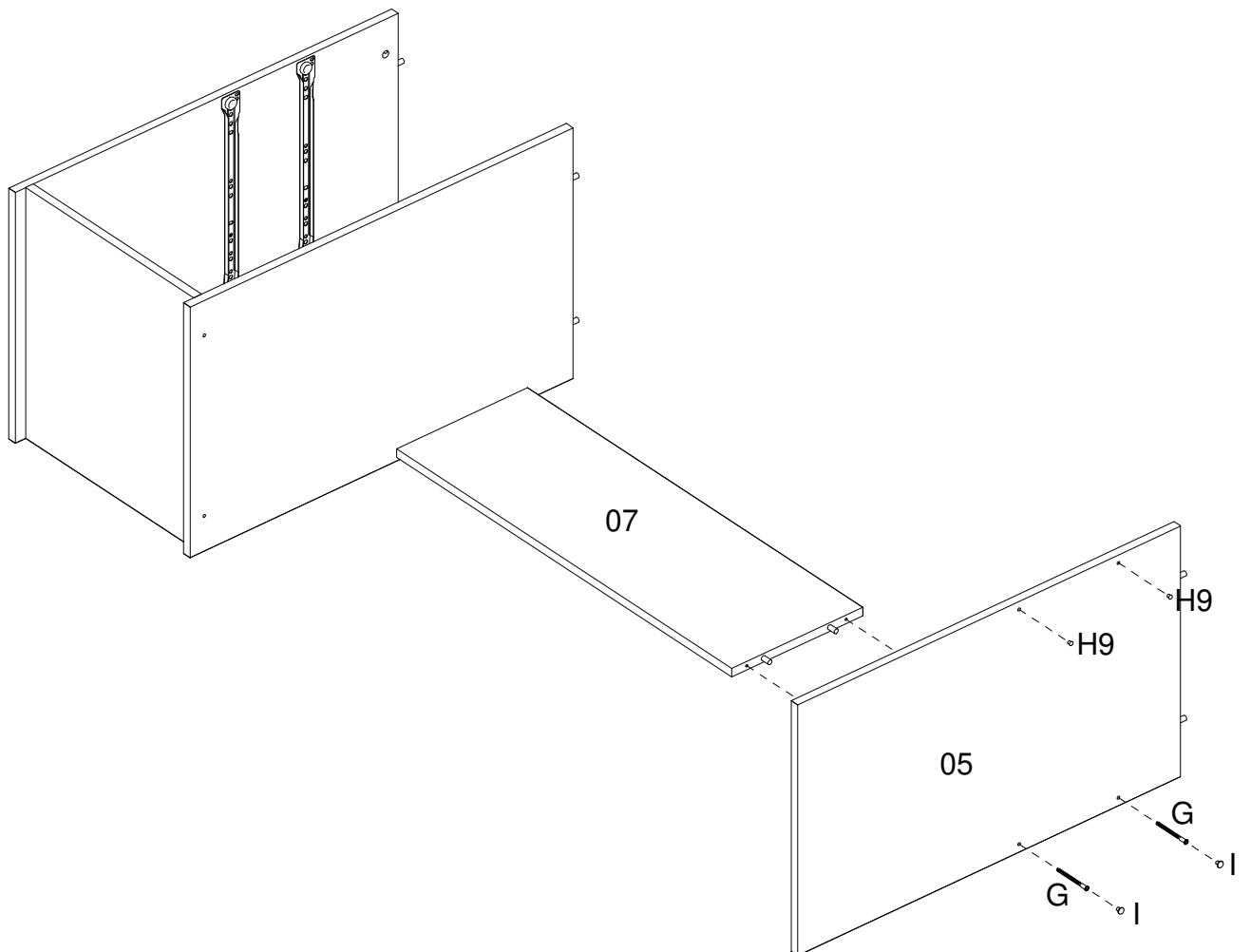



29

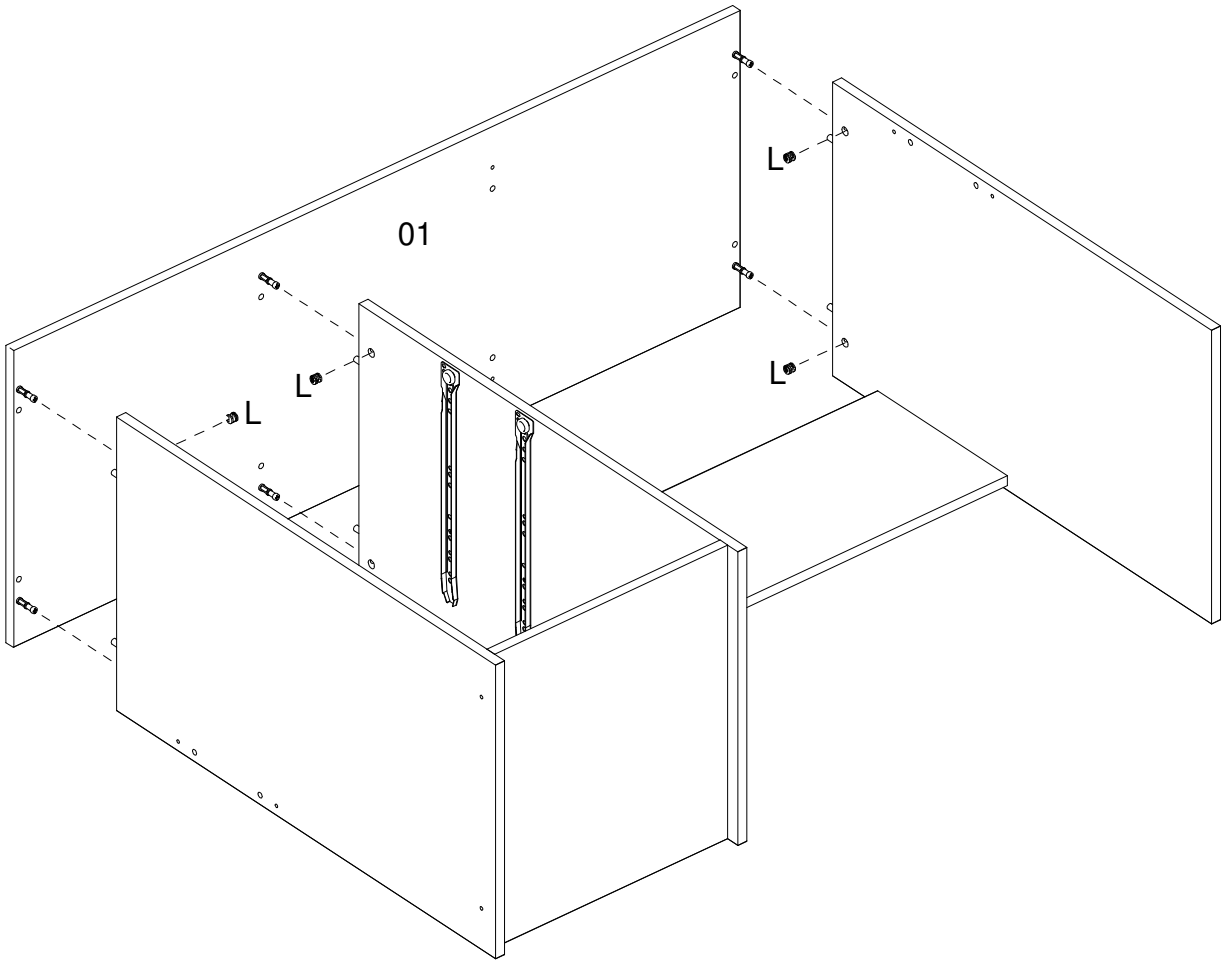

30

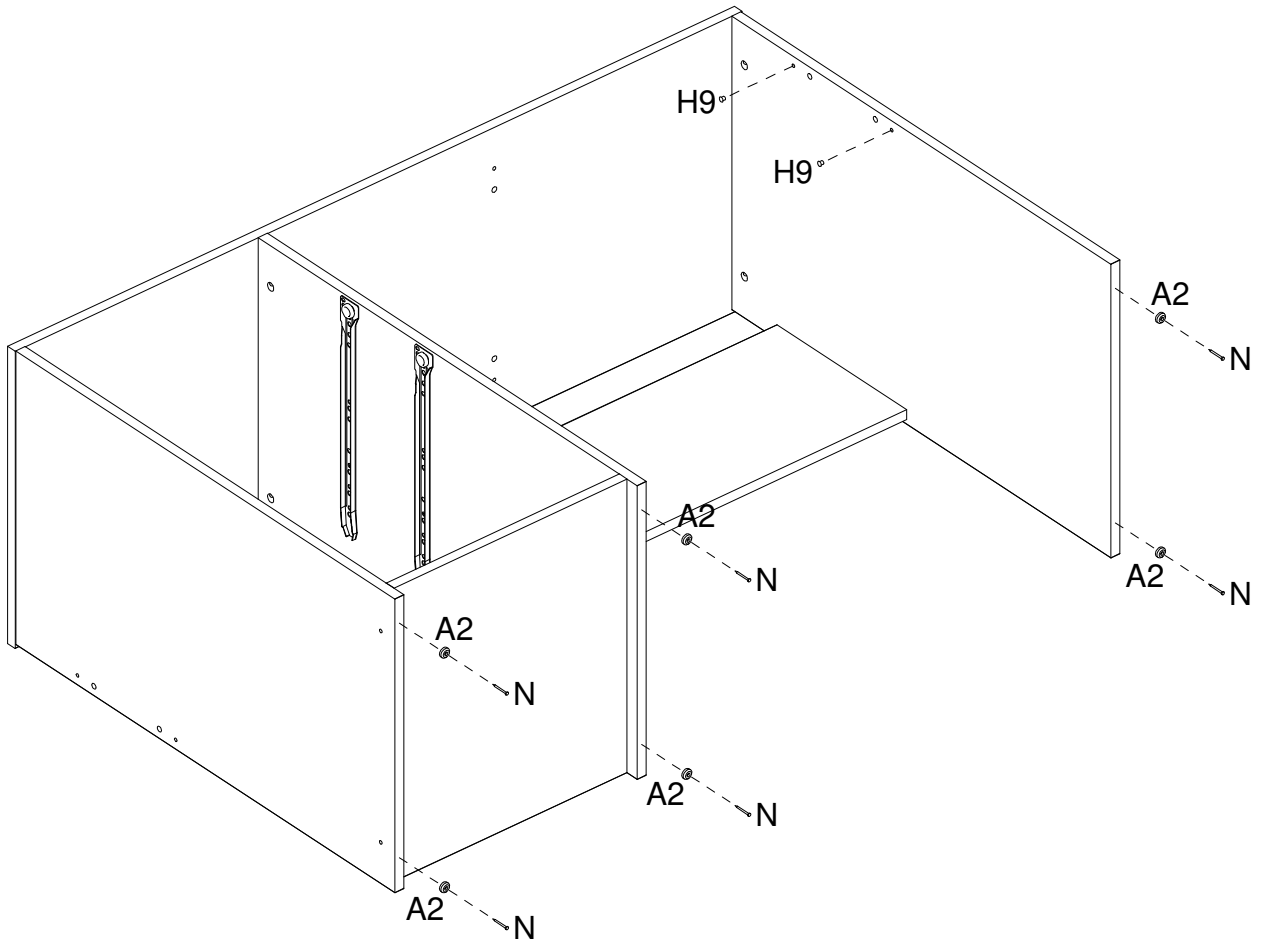

31

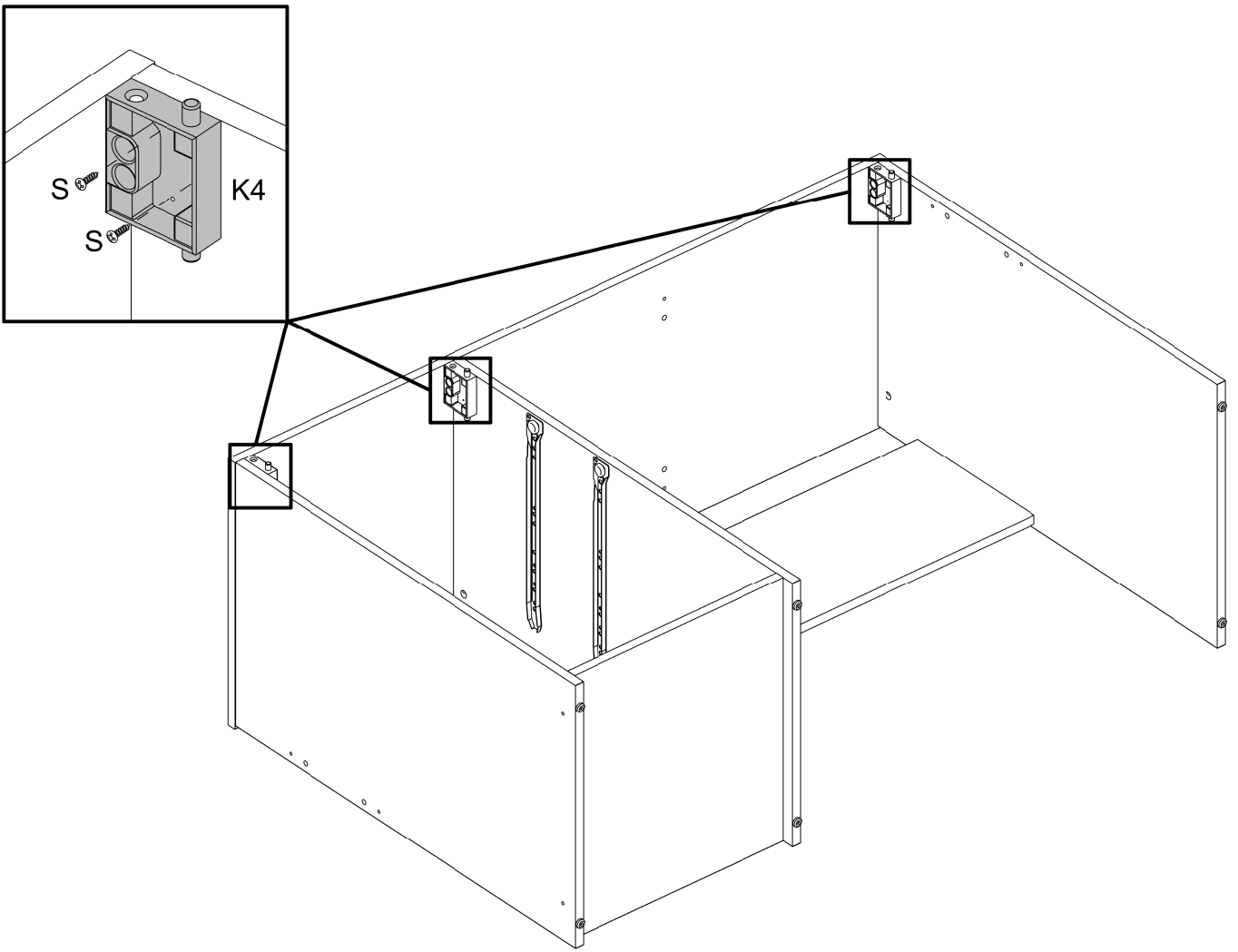

32

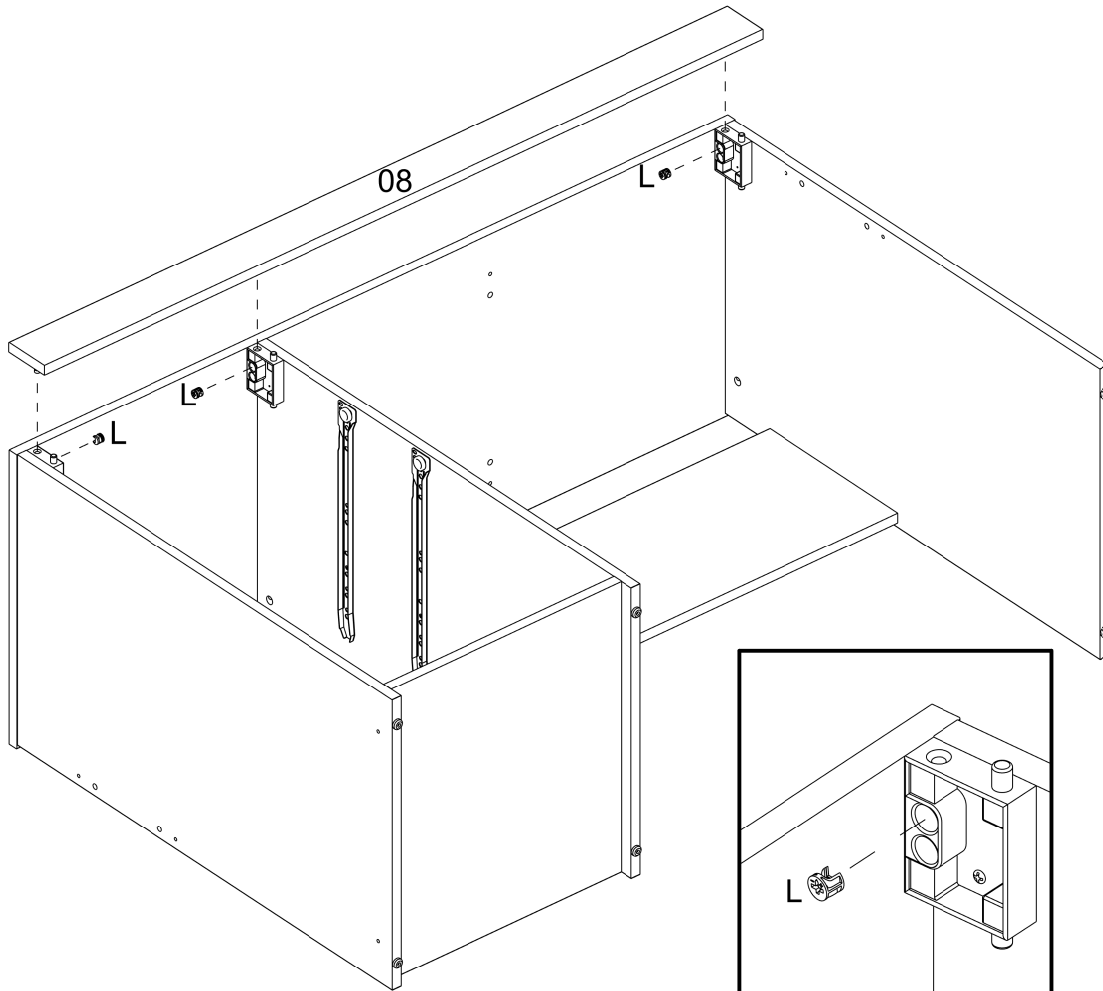

33

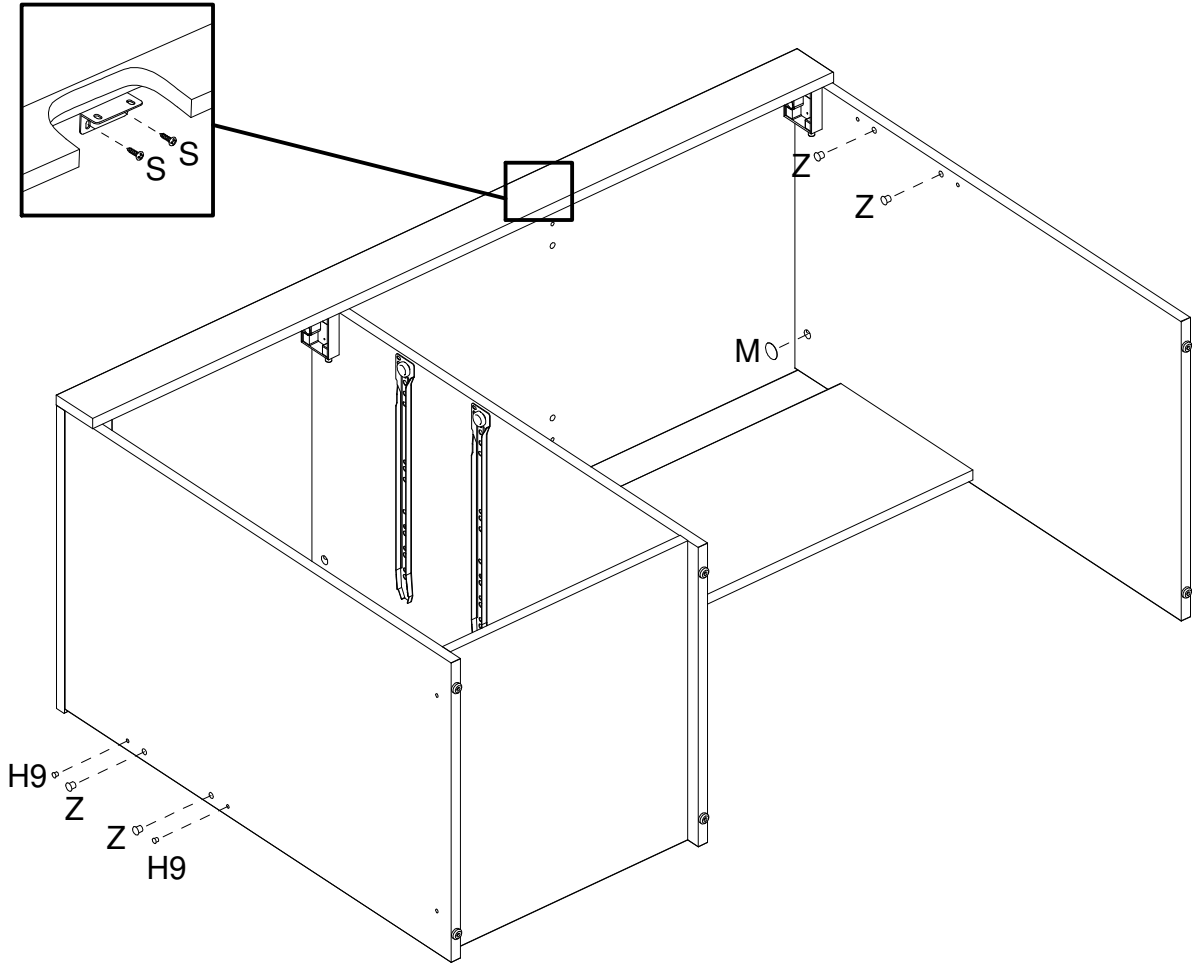

34

